

---

Alexander Schleicher GmbH & Co. Segelflugzeugbau  
D-36163 Poppenhausen (Wasserkuppe)

---

# Flight Manual

for the self-sustaining powered sailplane

## AS 33 Es

---

Model:	AS 33 Es
Serial Number:	<b>33023</b>
Registration:	<b>D-KTJL</b>
Data Sheet No.:	EASA.A.656
Issue:	01.11.2020



Pages identified by "Appr." are approved by EASA within the scope of type certification.

---

This sailplane is to operate only in compliance with the operating instructions and limitations contained herein.

---



## Section 0

Copyright © 2020

Alexander Schleicher GmbH & Co. Poppenhausen/Wasserkuppe

All rights reserved. Reprint or copying - also partially - only with the author's permission.

### 0.1 Record of revisions

Any revision of the present manual, except actual weighing data, must be recorded in the following table and, in case of approved sections, must be endorsed by the responsible airworthiness authority. The new or amended text in the revised page will be indicated by a black vertical line in the left hand margin, and the Revision No. and the date will be shown at the bottom of the page.

---

Issue: 01.11.2020 TMÖ  
Revision:

**0.1**





(

(



(

(



## 0.2 List of effective pages

Section	Page	Date	Section	Page	Date
Title Page	---	01.11.2020	3	approved	3.1 01.11.2020
					3.2 01.11.2020
0	0.1	01.11.2020			3.3 01.11.2020
	0.2	01.11.2020			3.4 01.11.2020
	0.3	01.11.2020			3.5 01.11.2020
	0.4	01.11.2020			3.6 01.11.2020
	0.5	01.11.2020			3.7 01.11.2020
	0.6	01.11.2020			3.8 01.11.2020
	0.7	01.11.2020			3.9 01.11.2020
					3.10 01.11.2020
1	1.1	01.11.2020			3.11 01.11.2020
	1.2	01.11.2020			3.12 01.11.2020
	1.3	01.11.2020			
	1.4	01.11.2020	4	approved	4.1 01.11.2020
	1.5	01.11.2020		approved	4.2 01.11.2020
	1.6	01.11.2020		approved	4.3 01.11.2020
	1.7	01.11.2020		approved	4.4 01.11.2020
				approved	4.5 01.11.2020
2	approved	2.1 01.11.2020		approved	4.6 28.04.2021
	approved	2.2 01.11.2020		approved	4.7 01.11.2020
	approved	2.3 01.11.2020		approved	4.8 01.11.2020
	approved	2.4 01.11.2020		approved	4.9 01.11.2020
	approved	2.5 01.11.2020		approved	4.10 01.11.2020
	approved	2.6 01.11.2020		approved	4.11 01.11.2020
	approved	2.7 01.11.2020		approved	4.12 01.11.2020
	approved	2.8 01.11.2020		approved	4.13 01.11.2020
	approved	2.9 01.11.2020		approved	4.14 01.11.2020
	approved	2.10 01.11.2020		approved	4.15 01.11.2020
	approved	2.11 01.11.2020		approved	4.16 01.11.2020
	approved	2.12 01.11.2020		approved	4.17 01.11.2020
	approved	2.13 01.11.2020		approved	4.18 01.11.2020
	approved	2.14 01.11.2020		approved	4.19 01.11.2020
	approved	2.15 01.11.2020		approved	4.20 01.11.2020
	approved	2.16 01.11.2020		approved	4.21 01.11.2020
	approved	2.17 01.11.2020		approved	4.22 01.11.2020
	approved	2.18 01.11.2020		approved	4.23 01.11.2020
				approved	4.24 01.11.2020

Issue: 01.11.2020 TMÖ

Revision:

(

(

.....

4	approved	4.25	01.11.2020	6	6.10	01.11.2020	
	approved	4.26	01.11.2020		6.11	01.11.2020	
	approved	4.27	01.11.2020		6.12	01.11.2020	
	approved	4.28	01.11.2020		6.13	01.11.2020	
	approved	4.29	01.11.2020				
	approved	4.30	01.11.2020		7	7.1	01.11.2020
	approved	4.31	01.11.2020			7.2	01.11.2020
	approved	4.32	01.11.2020			7.3	01.11.2020
	approved	4.33	01.11.2020			7.4	01.11.2020
	approved	4.34	01.11.2020			7.5	01.11.2020
approved	4.35	01.11.2020	7.6	01.11.2020			
			7.7	01.11.2020			
			7.8	01.11.2020			
			7.9	01.11.2020			
			7.10	01.11.2020			
5	approved	5.1	01.11.2020	7.11	01.11.2020		
	approved	5.2	01.11.2020	7.12	01.11.2020		
	approved	5.3	01.11.2020	7.13	01.11.2020		
	approved	5.4	01.11.2020	7.14	01.11.2020		
	approved	5.5	01.11.2020	7.15	01.11.2020		
	approved	5.6	01.11.2020	7.16	28.04.2021		
	approved	5.7	01.11.2020	7.17	01.11.2020		
	approved	5.8	01.11.2020	7.18	01.11.2020		
		5.9	01.11.2020	7.19	01.11.2020		
		5.10	01.11.2020	7.20	01.11.2020		
		5.11	01.11.2020	7.21	01.11.2020		
		5.12	01.11.2020	7.22	01.11.2020		
		5.13	01.11.2020	7.23	01.11.2020		
		5.14	01.11.2020	7.24	01.11.2020		
		5.15	01.11.2020	7.25	01.11.2020		
		5.16	01.11.2020	7.26	01.11.2020		
		5.17	01.11.2020	7.27	01.11.2020		
6		6.1	01.11.2020	7.28	01.11.2020		
		6.2	01.11.2020	7.29	01.11.2020		
		6.3	01.11.2020	7.30	01.11.2020		
		6.4	01.11.2020	7.31	01.11.2020		
		6.5	01.11.2020	7.32	01.11.2020		
		6.6	01.11.2020	7.33	01.11.2020		
		6.7	01.11.2020				
		6.8	01.11.2020				
		6.9	01.11.2020				

(

(

.....

8	8.1	01.11.2020
	8.2	01.11.2020
	8.3	01.11.2020
	8.4	01.11.2020
	8.5	01.11.2020
	8.6	01.11.2020
	8.7	01.11.2020
	8.8	01.11.2020
9	9.1	01.11.2020
	9.2	01.11.2020



### 0.3 Table of contents

#### Sections

- 0 Record of revision, List of effective pages, Table of contents
- 1 General  
(Section without approval)
- 2 Operating limitations and data  
(Approved section)
- 3 Emergency procedures  
(Approved section)
- 4 Normal operating procedures  
(Approved section)
- 5 Performance  
(Section partially approved)
- 6 Mass (weight) and balance, C.G. position  
(Section without approval)
- 7 Description of the sailplane, its systems and equipment  
(Section without approval)
- 8 Aircraft handling, care and maintenance  
(Section without approval)
- 9 Supplements





## **Section 1**

### **1 General**

- 1.1 Introduction
- 1.2 Type certification basis
- 1.3 Warnings, cautions and notes
- 1.4 Description and technical data
- 1.5 Three view drawing

## 1 General

### 1.1 Introduction

This Flight Manual has been prepared to provide pilots and instructors with information for the safe and efficient operation of the AS 33 Es sailplane.

This Manual includes the material required to be furnished to the pilot by the certification specification CS-22. It also contains supplemental data useful for the pilot supplied by the sailplane manufacturer.

The AS 33 Es is designed as a sailplane than can be operated either with 15 m span or with 18 m span. At the time this manual was created only the operation with 18 m span is certified for the AS 33 Es. This means, actually flights with 15 m span are prohibited! To avoid significant changes on the flight manual in terms of the later following certification the present flight manual already contains data and information for the operation of the aircraft with 15 m span. This should not bother the reader of the manual.

### 1.2 Type certification basis

This type of sustaining powered sailplane has been approved by the European Aviation Safety Agency (EASA) in accordance with CS-22, amendment 2, issued 5th March 2009.

Additionally the following requirement had to be complied with:

"Guidelines for the substantiation of the stress analysis for sailplanes and powered sailplanes made from glass and carbon fibre reinforced plastics", issued 1991.

Category of Airworthiness: Utility.

"Utility" refers to sailplanes and powered sailplanes used in normal gliding operation.

### 1.3 Warnings, cautions and notes

The following definitions apply to warnings, cautions and notes used in the Flight Manual:

**"WARNING"**

*means that non-compliance with the corresponding procedure leads to an immediate or important degradation of the flight safety.*

**"CAUTION"**

*means that non-compliance with the corresponding procedure leads to a minor or to a more or less long-term degradation of the flight safety.*

**"NOTE"**

*draws attention to any special item not directly related to safety, but which is important or unusual.*

## 1.4 Description and technical data

The AS 33 Es is a high performance, single-seat, flapped sailplane with a retractable sustainer power plant and exchangeable wingtips for 15 m and 18 m span. This makes it possible to fly within FAI 15m Class or 18m-Class specifications.

The AS 33 Es is suitable for record-breaking and competition flying. Not least, its pleasant flying characteristics make the AS 33 Es suitable for use in performance-orientated clubs.

The AS 33 Es is a mid-wing design, built mainly from carbon reinforced epoxy resin. Aramid, glass and Dyneema-fibres are used if appropriate. Along most of the trailing edge, the four-part wing provides two flaps, which also serve as ailerons (so called flaperons). In their role as ailerons, the inner and outer flaperons deflect in different degrees to allow for the necessities of thermalling. In landing flap setting, the inner flaperon deflects downwards strongly for steep approaches while retaining good manoeuvrability. The wing comprises four-part Schempp-Hirth airbrakes on the upper surface. The wing tips end in 0.55 m high winglets.

The tail is a damped T-tail. In the vertical tail there are probes for total pressure, static pressure, and total energy compensation. The pressures for the airspeed indicator and for the altimeter are taken from orifices in the tail boom (static pressure) and in the fuselage nose (total pressure).

The spring mounted retractable main landing gear has a 5" wheel and is equipped with a hydraulic disc brake which is operated when the airbrakes are fully extended.

A two-cylinder, two-stroke engine can be extracted from the fuselage and helps the glider over areas of little or no lift.

All gaps at the movable control surfaces are covered with Mylar-tape. Except the rudder, all control surfaces are additionally sealed with Teflon tape.

**Technical data:**

(Metric system)

Span (incl. winglets)	18,0	15,0	m
Fuselage length	6,59	6,59	m
Height (Fin and fixed tail wheel)	1,3	1,3	m
Height (Fin and retractable tail wheel)	1,4	1,4	m
Max. Take-off Mass	600,0	550,0	kg
Wing chord (mean aerodynamic)	0,56	0,59	m
Wing area	10,0	8,8	m <sup>2</sup>
Wing loading:			
- minimal	~37,0	~41,0	kg/m <sup>2</sup>
- maximal	60,0	62,5	kg/m <sup>2</sup>

(British and US system)

Span (incl. Winglets)	59.06	49.21	ft
Fuselage length	21.60	21.60	ft
Height (Fin and fixed tail wheel)	4.27	4.27	ft
Height (Fin and retractable tail wheel)	4.59	4.59	ft
Max. Take-off Mass	1322	1212	lbs
Wing chord (mean aerodynamic)	1.84	1.94	ft
Wing area	107.6	94.7	m <sup>2</sup>
Wing loading:			
- minimal	~7.58	~8.38	lbs/ft <sup>2</sup>
- maximal	12.29	12.8	lbs/ft <sup>2</sup>

**General view**

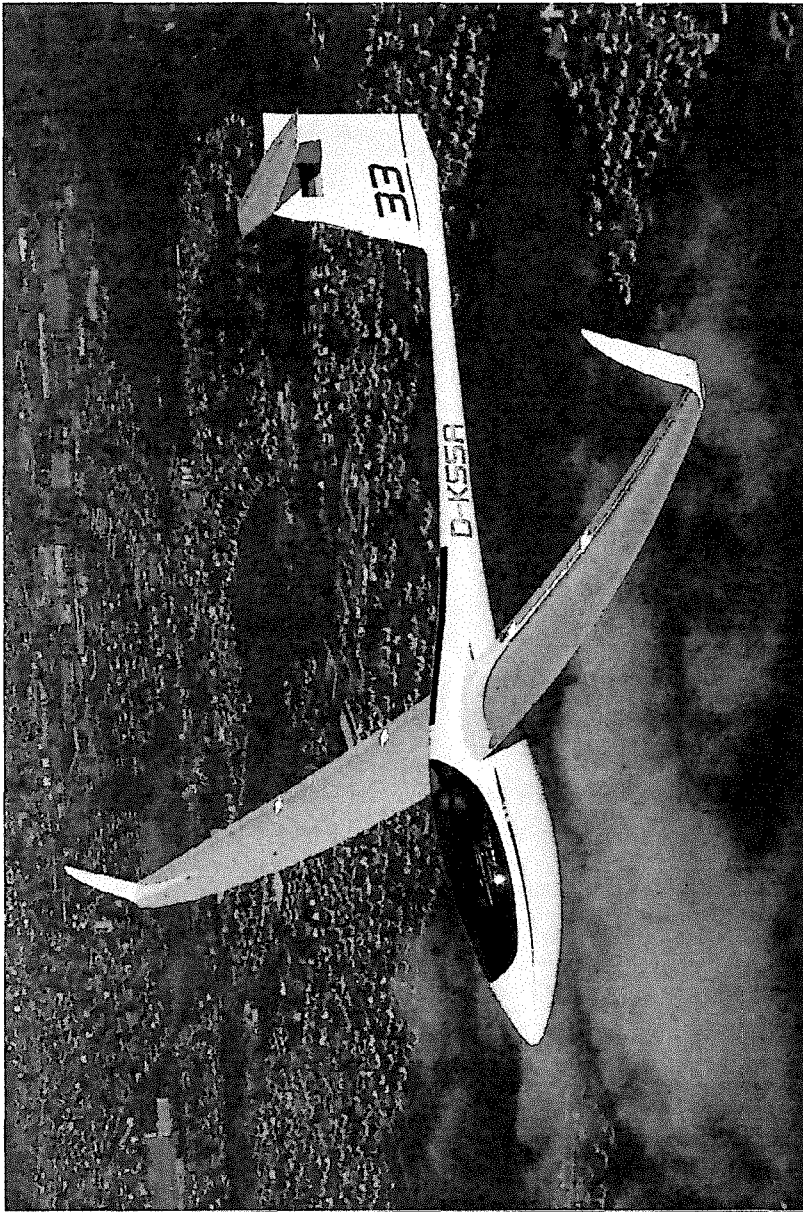

Issue: 01.11.2020 TMO  
Revision:

1.5 Three view drawing

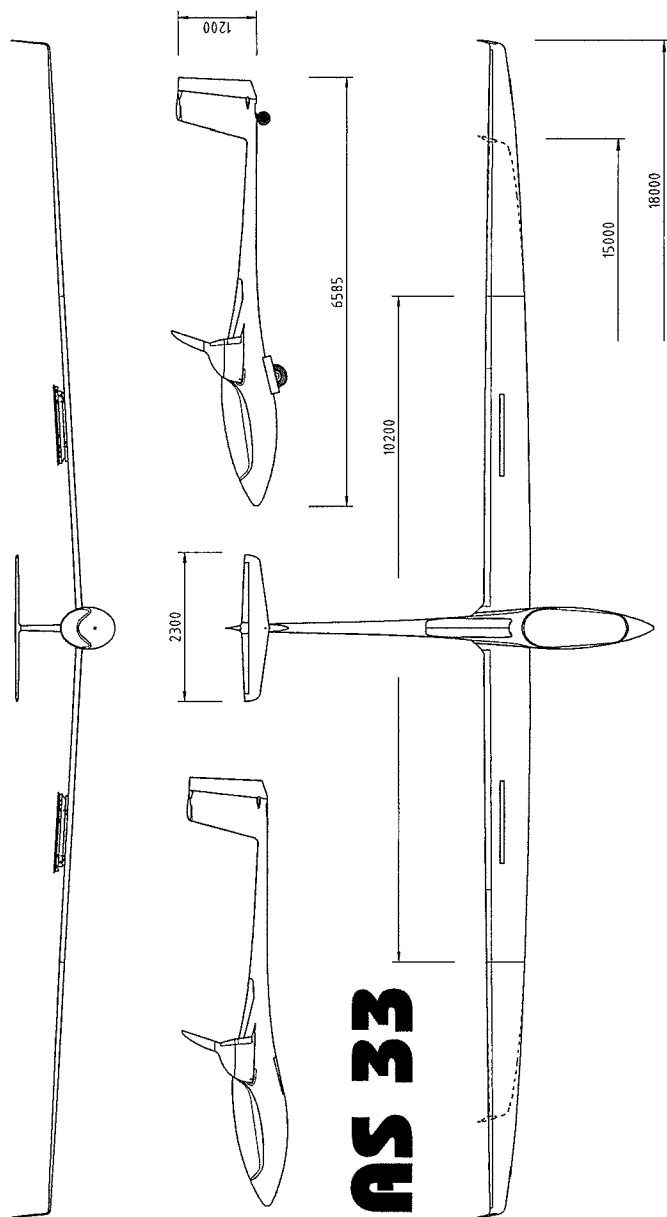

(

(



## Section 2

### 2 Limitations

- 2.1 Introduction
- 2.2 Airspeed
- 2.3 Airspeed indicator markings
- 2.4 Power-plant, fuel and oil
- 2.5 Power-plant instrument markings
- 2.6 Weight (mass)
- 2.7 Centre of gravity
- 2.8 Approved manoeuvres
- 2.9 Manoeuvring load factors
- 2.10 Flight crew
- 2.11 Kinds of operation
- 2.12 Minimum equipment
- 2.13 Aerotow, winch and autotow launching
- 2.14 Other limitations
- 2.15 Limitations placards

## 2 Limitations

### 2.1 Introduction

Section 2 includes operating limitations, instrument markings and basic placards necessary for the safe operation of the AS 33 Es and its standard systems and standard equipment as provided by the manufacturer.

### 2.2 Airspeed

Airspeed limitations (indicated airspeed IAS) and their operational significance are shown below:

	Speed	IAS	Remarks
VNE	<b>Never exceed speed</b>	270 km/h 145 kts 167 mph	Do not exceed this speed in any operation and do not use more than 1/3 of control deflection.
VRA	<b>Rough air speed</b>	200 km/h 108 kts 124 mph	Do not exceed this speed except in smooth air, and then only with caution. Examples of rough air are leewave rotors, thunderclouds, visible whirlwinds, or over mountain crests.

Issue: 01.11.2020 TMÓ  
Revision:

<b>VA</b>	<b>Manoeuvring speed</b>	200 km/h 108 kts 124 mph	Do not make full or abrupt control movement above this speed, because under certain conditions the sailplane structure may be overstressed by full control movement.
<b>VFE</b>	<b>Maximum Flap extended speeds</b>	<b>1 – 2 – 3</b> <b>4</b> 270 km/h 145 kts 167 mph <b>N – 5 – 6</b> 200 km/h 108 kts 124 mph <b>L</b> 150 km/h 81 kts 93 mph	Do not exceed these speeds with the flap in position of the given numbers.
<b>VW</b>	<b>Maximum Winch-launching speed</b>	140 km/h 75.5 kts 87 mph	Do not exceed this speed during winch- or autotow launching.
<b>VT</b>	<b>Maximum Aero-towing speed</b>	180 km/h 97 kts 111 mph	Do not exceed this speed during aero-towing.
<b>VLO</b>	<b>Maximum Landing Gear Operating speed</b>	200 km/h 108 kts 124 mph	Do not extend or retract the landing gear above this speed.
	<b>Maximum speed with engine extended</b>	140 km/h 75.5 kts 87 mph	Do not exceed this speed with the engine extended.

<b>VPO</b> max	<b>Maximum speed for extending and re- tracting the engine</b>	140 km/h 75.5 kts 87 mph	Do not extend or retract the retractable power- plant outside of this speed range.
<b>VPO</b> min	<b>Minimum speed for extending and re- tracting the engine</b>	85 km/h 45 kts 52 mph	

Issue: 01.11.2020 TMÖ  
Revision:

### 2.3 Airspeed indicator markings

Airspeed indicator markings and their colour code significance are shown below:

Marking	(IAS) value or range	Meaning
White arc	97 - 200 km/h 52 - 108 kts 60 - 124 mph	Positive Flap Operating Range
WK N/5/6	200 km/h 108 kts 124 mph	Maximum Speed in Flap Settings N, 5 and 6
WK L	150 km/h 81 kts 93 mph	Maximum Speed in Landing Flap Setting
Green arc	105 - 200 km/h 57 - 108 kts 65 - 124 mph	Normal Operating Range
Yellow arc	200 - 270 km/h 108 - 145 kts 124 - 167 mph	Manoeuvres must be conducted with caution and only in smooth air
Red line	270 km/h 145 kts 167 mph	Maximum speed for all operations
Yellow triangle	100 km/h 54 kts 62 mph	Approach speed at maximum weight <b>without</b> water ballast
Blue line	95 km/h 51 kts 59 mph	Best rate-of-climb speed $V_y$ at maximum weight <b>without</b> water ballast

## 2.4 Power-plant, fuel and oil



Engine manufacturer:	SOLO Kleinmotoren GmbH
Engine model:	SOLO Typ 2350e
Max. power, take-off:	<i>Not applicable</i>
Max. engine rpm, take-off:	<i>Not applicable</i>
Max. power, continuous:	24 PS / 18 kW
Max. engine rpm, continuous:	5400 U/min
Max. cylinder head temperature:	275°C
Fuel:	2-stroke mixture from AVGAS 100LL or unleaded MOGAS 95 ROZ
Oil grade:	Oil-to-fuel mixture 1:40 2-stroke oil Castrol RS 2T, Castrol Super TT, Castrol TTS or Castrol Go!2T. If none of these oils is available, alternatively two stroke oil with the designation JASO FC can be used.
Total quantity of fuel:	7.0 Ltrs (optional: 11,0 Ltrs)
thereof usable:	6.8 Ltrs
Propeller manufacturer:	Alexander Schleicher GmbH & Co
Propeller model:	AS2F1-3/L100-56-N2

---

Issue: 01.11.2020 TMO  
Revision:

## 2.5 Power-plant instrument markings

The following table explains the meaning of the different lights of the power-plant instrument:

Symbol	Green light	Yellow light	Red light
RPM	4400 to 5200 rpm	5200 to 5400 rpm	> 5400 rpm, continuous alarm, ignition is switched off
BAT	Flashes red: Battery voltage below 11.5 V		
	Green light: power-plant is extended		
	<p>Flashes red, alarm sound: pay attention to LCD display! (also see section 3.7)</p> <p>"SWITCH R" or "SWITCH E": Time for extension or retraction was too long, probably an end switch is faulty.</p> <p>"INS_TANK": Connection to fuel tank sensor is broken</p> <p>"FUZE": Circuit breaker of the jackscrew disconnected</p> <p>"MOT LOCK": Starter motor blocked</p> <p>"ERROR CAN_MISS": Connection of the CAN-Bus between power-plant instrument and starter motor controller broken.</p> <p>"ERROR SENSOR": missing sensor signal of the starter motor</p> <p>"MANUALLY FUELCOCK": manual fuel valve operation</p>		
	Green light: power plant is retracted		

A continuous alarm sound points to a limit being violated (e.g. rpm, fuel capacity...). A pulsing alarm points to a handling note. See LCD display for explanation.

The permanent display of the power-plant instrument LCD indicates the RPM (four digits on the left-hand side) and the fuel quantity of the fuselage tank in litres (two digits on the right-hand side, in steps of half litres):

4500 6,0

By pressing the white button, switching to further displays is possible:

Press once, engine battery voltage:

12,8V

Press twice, starter battery voltage:

Um 13,5V

Press three times, starter motor current:

Imot 62A

Press four times, starter motor temperature:

Stat 61°

Press five times, starter motor controller temperature:

PwrT 54°

Press six times, propeller position:

Pos: 5

Press seven times, engine elapsed time indication:

7,56h

Press eight times, value of tank calibration (only with retracted engine):

[100]

Press nine times, tank calibration (only with retracted engine):

Calibr.?

Tank-calibration is described in section 7.



## 2.6 Weight (mass)

Span:	<b>18 m / 59 ft</b>	<b>15 m / 49 ft</b>
Maximum Take-off Mass	600 kg 1322 lbs	550 kg 1212 lbs
Maximum Landing Mass	600 kg 1322 lbs	550 kg 1212 lbs
Max. mass of all non-lifting parts	300 kg 661 lbs	
Max. mass on pilot seat	115 kg 253.5 lbs	
Max. mass in the baggage compartment behind headrest	12 kg 26 lbs	
Max. mass in the baggage compartment left to the main landing gear (when flying without fuel tank)	5 kg 11 lbs	
Max. trim weight in the compartment at the upper vertical	3,6 kg 7.9 lbs	

## 2.7 Centre of gravity

Centre of gravity range (for flight):

Span:	18 m	15 m	
Foremost limit	220 mm 8.66 in	220 mm 8.66 in	aft of RP
Rearmost limit	330 mm 13.0 in	330 mm 13.0 in	aft of RP

"RP" stands for "Reference Point" (datum), which is located at the leading edge of the wing at the wing root rib. An example of a C.G. position calculation as well as additional remarks are shown in Section 6.

## 2.8 Approved manoeuvres

This sailplane is certified for use in normal gliding operation according to Airworthiness Category U, "Utility"; see also sections 2.7, 2.9, and 2.10.

Aerobatic figures are not approved.

## 2.9 Manoeuvring load factors

The airworthiness requirements result in the following limits for the maximum permissible manoeuvring load factors:

at an airspeed of 200 km/h (108 kts, 124 mph):

maximum positive load factor: + 5.3

maximum negative load factor: - 2.65

With increasing air speeds, these values will reduce.

at an airspeed of 270 km/h (145 kts, 167 mph):

maximum positive load factor: + 4.0

maximum negative load factor: - 1.5

Maximum permissible manoeuvring load factors with airbrakes extended:

at an airspeed of 270 km/h (145 kts, 167 mph):

maximum positive load factor: + 3.05

maximum negative load factor: 0.0

Maximum permissible manoeuvring load factors with flap in landing setting:

at an airspeed of 150 km/h (81 kts, 93 mph):

maximum positive load factor: + 4.0

With increasing aileron deflections (up to the maximum permitted) the permissible load factors reduce by 1/3.

## 2.10 Flight crew

The crew of the AS 33 Es is one pilot.

Pilots weighing less than the minimum load (incl. parachute) must use additional trim ballast plates. Please refer to the "Weight (mass) and balance form" in Section 6 and the description of trim ballast plates in Section 7.11.

In addition, the minimum cockpit load is shown in the Operating Limitations Placard in the cockpit (DATA and LOADING PLACARD).

## 2.11 Kinds of operation

Flights may be carried out in accordance with day VFR.

## 2.12 Minimum equipment

Minimum Equipment consists of:

- 1 ASI indicating up to at least 300 km/h (162 kts, 187 mph)
- 1 Altimeter
- 1 Magnetic Compass
- 1 4-part safety harness (symmetrical)
- 1 Parachute or cushion for back rest (~ 8 cm thickness)
- 1 Outside air thermometer

With the engine installed:

- 1 Power-plant instrument, ILEC MCU type AS 33 Es

### **NOTE**

*The temperature indication can be provided by an on-board computer.*

The list of equipment that must be operative for all flights consists of this listed minimum equipment as well as equipment required for the flight by the associated operational rules. Such implemented rules can cover operational requirements, airspace requirements and any other applicable requirements to the intended operation.

Approved equipment is listed in the Maintenance Manual in Section 12.1. The manufacturer recommends installing a yaw string on top of the canopy.

## 2.13 Aerotow, winch and autotow launching

Launching by aerotow is approved using the towing release in the fuselage nose. Winch and autotow launches are approved using the tow release in front of the main landing gear.

The flap settings 1 - 4 are not permitted for aerotow, winch and autotow launches.

The AS 33 Es is not approved for take-off by sole means of its own power. Launches have to be performed with the engine retracted.

The maximum permissible launch speeds are:

aerotowing 180 km/h (98 kts, 111 mph)

winch launch 140 km/h (75.5 kts, 87 mph)

For winch launch, a weak link of 850 daN  $\pm 10\%$  (1910 lbs, brown) must be used in the launch cable or tow rope. Without water ballast, a weak link of 750 daN  $\pm 10\%$  (1686 lbs, red) may be used.

For aerotow, a weak link according to the tow plane must be used, not stronger than 750 daN  $\pm 10\%$  (1686 lbs, red). Besides other regulations, which may exist, the tow rope must be a textile rope not less than 40 m (130 ft) or more than 60 m (200 ft) in length.

Weak link colours are not binding; this information refers to the colour scheme of the Tost company.

## 2.14 Other limitations

### **Water Ballast**

Section 6 describes what amount of water may be used to stay within the limitations of mass and c.g.

After water ballast has been loaded, it has to be checked that the ballast is distributed symmetrically. This is the case only if the wings can be held level with ease.

Only pure water may be used, without any additives.

**WARNING**

*Flying with water ballast in air mass temperatures of less than 3°C is not permitted. At outside temperatures of less than 3°C the water ballast has to be jettisoned.*

**WARNING**

*Due to reasons of flutter safety Flight Level FL160 (5000m pressure altitude above 1013 hPa) may not be exceeded with water ballast in the wings.*

**WARNING**

*Spinning with water ballast is not permitted!*

See section 4.5 for more information about water ballast.

2.15 Limitations placards

This placard is fixed to the left-hand cockpit side wall and contains the most important mass (weight) and speed limitations.

Segefluggzeugbau A. Schleicher GmbH & Co. Poppenhausen

Model: **AS 33 Es** Serial-No.:

**DATA PLACARD**

Max. permissible speeds

Calm air:	145 kts	270 km/h
Winch- or autotow launching:	75.5 kts	140 km/h
Aerotow:	97 kts	180 km/h
Extending landing gear:	108 kts	200 km/h
Manoeuvring speed:	108 kts	200 km/h

Speed limits with power-plant for extension / retraction:

with power-plant extended:	49 - 75.5 kts	90 - 140 km/h
Weak link for winch launch:	75.5 kts	140 km/h

Weak link for aerotow appropriate for towing airplane, max.:  750 daN  $\pm 10\%$

Tire pressure

Main wheel:	49.3 - 52.3 psi	3.4 - 3.6 bar
Tail wheel (fixed):	34.1 - 37.1 psi	2.4 - 2.6 bar
Tail wheel (retractable):	56.5 - 59.5 psi	3.9 - 4.1 bar

**LOADING PLACARD**

15 m		18 m	
kg	lbs	kg	lbs
Empty mass (weight):			
Max. mass (weight):			
550 kg	1212 lbs	600 kg	1322 lbs
Min. seat load			
Max. seat load			
Max. total load in fuselage			

That applies for following installed weights:

- Power-plant installed
- Avionic Batt. 1 (footrest)
- Engine Batt. M1 (footrest)
- Avionic Batt. 2 (baggage comp.)
- Engine Batt. M2 (eng. comp.)
- Avionic Batt. 3 (fin)

With deviating loading, note AFM section 6!  
Usable fuel 6.8 Litres / 1.8 US Gal. (5.0 kg / 11.0 lb)

Note:

The configuration during weighting must be noted on the loading placard.

If the optional extension of the fuel tank is installed then the following data placard must be used:

Segelflugzeugbau A. Schleicher GmbH & Co. Poppenhausen Model: <b>AS 33 Es</b> Serial No.: _____		<b>LOADING PLACARD</b>	
<b>DATA PLACARD</b>		15 m                      18 m	
Max. permissible speeds	145 kts                      270 km/h 75.5 kts                      140 km/h 37 kts                          180 km/h 108 kts                      200 km/h 108 kts                      200 km/h	Empty mass (weight):	kg                      kg lbs                      lbs
Calm air: Winch- or autotow launching: Aerotow: Extending landing gear: Manoeuvring speed:	49 - 75.5 kts                      90 - 140 km/h 75.5 kts                          140 km/h _____                      850 daN ±10% _____                      750 daN ±10%	Max. mass (weight):	550 kg                      600 kg 1212 lbs                      1322 lbs
Speed limits with power-plant for extension / retraction: with power-plant extended:	_____                      _____ _____                      _____	Min. seat load	lbs                      kg
Weak link for winch launch: Weak link for aerotow appropriate for towing airplane, max.:	_____                      _____ _____                      _____	Max. seat load	lbs                      kg
Tire pressure	Main wheel: _____ Tail wheel (fixed): _____ Tail wheel (retractable): _____	Max. total load in fuselage	lbs                      kg
That applies for following installed weights: <input type="checkbox"/> Power-plant installed <input type="checkbox"/> Avionic Batt. 1 (footrest) <input type="checkbox"/> Engine Batt. M1 (footrest) <input type="checkbox"/> Avionic Batt. 2 (bagg. comp.) <input type="checkbox"/> Engine Batt. M2 (eng. comp.) <input type="checkbox"/> Avionic Batt. 3 (fin)		With deviating loading, note AFM section 6! Usable fuel 10.8 Litres / 2.85 US Gal. (7.9 kg / 17.4 lb)	



This placard is to be fixed near the previous data placard:

**Aerobatics and cloud flying  
are not permitted!**

If an attachment for trim weights is installed in front of the front pedals, then this placard is affixed on the right-hand side of the cockpit side wall.

 **Prior to take-off, check  
weight of the trim plates  
and their secure fixing**

---

**1 Plate (1 kg; 2.2 lbs) in front  
of the pedals equals a  
pilot mass of 2.2 kg (4.85 lbs)**

This placard is fixed to the tube between the front lift pins.

Baggage com-  
partment load  
**max. 12 kg**  
**(26 lbs)**  
only soft parts

This placard is fixed on the left cockpit side wall in the area of the main landing gear (only visible when fuel tank is removed):

Baggage com-  
partment load  
**max. 5 kg**  
**(11 lbs)**  
only soft parts

This placard is attached to the compartment for trim weight at the upper vertical fin.

A maximum loading of  
**3.6 kg (7.9 lbs)**  
must **not** be exceeded

This placard is located at the engine compartment above the fuel filler connector.

**Avgas 100 LL or  
Super (min 95 RON/ROZ)**

with 2-stroke Oil Castrol RS 2T  
Mixing-ratio: 1:40

Fuel capacity = 7.0 Ltrs 1.85 US Gal.  
Non usable fuel = 0.2 Ltrs 0.05 US Gal.

If the optional extension of the fuel tank is installed then the following placard must be used instead:

**Avgas 100 LL or  
Super (min 95 RON/ROZ)**

with 2-stroke Oil Castrol RS 2T  
Mixing-ratio: 1:40

Fuel capacity = 11 Ltrs 2.9 US Gal.  
Non usable fuel = 0.2 Ltrs 0.05 US Gal.

## **Section 3**

### **3 Emergency procedures**

- 3.1 Introduction
- 3.2 Jettisoning of canopy
- 3.3 Bailing out
- 3.4 Stall recovery
- 3.5 Spin recovery
- 3.6 Spiral dive recovery
- 3.7 Engine failure
- 3.8 Fire
- 3.9 Other emergencies
- 3.10 Other emergencies in powered flight

### **3 Emergency procedures**

#### **3.1 Introduction**

This section provides checklists which describe briefly the recommended procedures to follow in emergencies. Afterwards a more detailed description follows.

#### **EMERGENCY PROCEDURES**

##### **Canopy jettison**

- ① Pull both the left- and right-hand red levers at the canopy frame all the way back.
- ② Pull canopy rearward and up.

##### **Bailing out**

- ① Push up instrument panel.
- ② Open safety harness.
- ③ Roll over cockpit side.
- ④ Push off strongly.
- ⑤ Caution: Wing and tailplane.
- ⑥ Pull parachute.

**Spin recovery**

- ① Apply full rudder opposite to the direction of the spin  
*and at the same time*
- ② Ease the stick forward until rotations ceases
- ③ Center the rudder and ease out of the ensuing dive!

**NOTE**

*Neutral aileron supports recovery.*

**CAUTION**

*When flap setting is 5, 6 or L during spin, change flap to negative setting (e.g. 4) while easing out the dive.*



### 3.2 Jettisoning of canopy

Pull canopy jettison (red levers mounted left and right on the canopy frame) and pull canopy rearwards and up!

#### **CAUTION**

*Push the canopy open with the canopy jettison handles. Do not push up the canopy above the head directly with the hands. The "Röger-hook" will hold the rear end of the canopy down, to make it swivel around its trailing edge.*

In a vertical dive, the air loads on the canopy may be high. With some yaw, however, low pressure builds up over the canopy. Therefore, apply some rudder in this case.

### 3.3 Bailing out

If bailing out becomes inevitable, first the canopy is jettisoned, and only then should the seat harness be released.

Push instrument panel up (if this was not done in the course of jettisoning the canopy). Get up or simply roll over cockpit side.

When jumping, push yourself away from the aircraft as strongly as possible. Try to avoid contact with wing leading edges or tail surfaces.

### 3.4 Stall recovery

In straight or circling flight, relaxing the back pressure on the stick will always lead to recovery. Due to its aerodynamic qualities the AS 33 Es will immediately regain airspeed.

If the glider drops a wing, do not try to counteract rolling motion with the aileron. Relax back pressure on the stick and use the rudder.

### 3.5 Spin recovery

- ① Apply full rudder opposite to the direction of the spin *and at the same time*
- ② ease the stick forward (means, give in to the pressure of the stick) until rotation ceases and sound airflow is established again.
- ③ Center the rudder and ease out the ensuing dive.

**CAUTION**

*Furthermore, spin recovery will be accomplished more quickly if flap deflection is reduced.*

*When flap setting is 5, 6 or L during spin it is advisable to use negative flap setting (e.g. setting 4) to avoid exceeding the maximum speed when easing out the dive.*

*Spinning is not noticeably affected by extending the air brakes, but this increases the height loss and reduces the permissible load factor during recovery. It is therefore advisable to keep the airbrakes retracted.*

**WARNING**

*Spinning in the landing-flap setting is strictly prohibited. If a spin should inadvertently develop while being in this flap setting, the flaps should immediately be set to neutral (flap setting N) before the limits of flap setting L are reached (maximum speed of 150 km/h and maximum load factor of 4g).*

**NOTE**

*Water ballast does not have noticeable influence on spinning qualities except that recovery speeds are higher and as a consequence greater losses in altitude are experienced.*



### 3.6 Spiral dive recovery

Depending on the aileron position in a spin with forward C.G. positions in which the AS 33 Es does not sustain a steady spin anymore, a spiral dive or a slipping turn similar to a spiral dive will develop immediately or after a few turns.

In contrast to a spin, a spiral dive is characterized by high g-loads. Therefore do not pull further, but

- ① Release stick
- ② Reduce bank angle with rudder and aileron against direction of turn
- ③ Gently pull out of the dive

### 3.7 Engine failure

#### Failure at safe altitude

Check the following points:

- Error message from power-plant instrument?
- Engine switch at middle position "ON"  ?
- Fuel content in fuselage tank?

If the above points turn out to be alright, the fault cannot be rectified in flight. Retract power-plant according to checklist and continue flight as pure sailplane.

If the red light next to  flashes on the power-plant instrument, a pulsing alarm sounds and the LCD-display shows the following:

**SWITCH E:** While the engine was being extracted, the power-plant instrument did not get a signal from the end switch for too long. Possible causes are a weak battery or a defective gas spring. Pressing the white button on the power plant instrument restarts the extraction.



**INS\_TANK:** The electric connection to the tank sensor is interrupted. This alone is not the reason for an engine failure (as long as the tank is on board and the fuel lines are connected).

**MANUALLY FUELCOCK:** The manual fuel valve was triggered. Press fuel valve manually open button, confirm the message at the power-plant instrument and try to start the engine again.

**FUSE:** The circuit breaker of the jackscrew is disconnected. Pressing the white button on the power-plant instrument stops the alarm sound and – if the power-plant is supposed to be extended or retracted – resets the circuit breaker.

**CAUTION**

*Do not fly faster than 120 km/h (65 kts) in an emergency situation without information on the display of the power-plant instrument, because there is no control of rpms any more.*

**Failure at low altitude**

If no terrain suitable for a safe landing can be reached any more, the power-plant should be retracted as far as possible:

- ① Reduce airspeed (100 km/h, 54 kts)
- ② Engine switch to "OFF"
- ③ Close fuel valve manually and confirm the corresponding warning message at the power-plant instrument (white button)
- ④ Prior to touch-down, toggle main switch off

Retracting the engine not only improves gliding performance but also reduces the risk in case of an out-landing.

**Heavy vibrations of the power-plant**

Shut down and retract the engine as normal. The propeller has possibly been damaged, causing an imbalance. Do not re-start the power-plant.

### Low engine or starter battery voltage

If the BAT-light on the power-plant instrument starts to flash, the motor battery is discharged. There is usually enough energy left to retract the engine. The power consumption of the power-plant instrument is also very low.

#### CAUTION

*With an empty engine battery the engine does not cease running. But since there is no control for the rpms any more, a speed of 120 km/h (65 kts) must not be exceeded. Fly to a safe terrain for landing, because the engine cannot be retracted anymore.*

If on the power-plant instrument the red LED next to  is flashing and "UM 11,0V" (or lower) is shown at the display, the state of charge of the starter battery is too low. Then it is neither possible to extract nor to retract the power-plant, because the vertical alignment of the propeller cannot be ensured. Also the starter is blocked to avoid damage of the starter battery.

In contrast, it does not have any consequences if the voltage of the starter battery drops during start-up.

#### WARNING

*A stopped power-plant, not retractable any more, decreases the glide ratio dramatically.*

## 3.8 Fire

If a fire is detected in the engine bay or at the engine:

- ① Engine switch to "OFF" .
- ② Reduce speed (100 km/h, 54 kts).
- ③ Close fuel valve manually and confirm the corresponding warning message at the power-plant instrument (white button).
- ④ Land as quickly as possible.
- ⑤ Extinguish fire.



Retracting the engine not only improves gliding performance but also reduces the risk in case of an out-landing.

### 3.9 Other emergencies

#### **Jammed elevator control system**

In case of an emergency it does not always occur to the pilot that, with the elevator control system jammed, the flaps still afford some measure of pitch control for improving the situation for bailing out or even perhaps eliminating the need to do so. Setting the flaps to a more negative position causes an increase in pitch and speed. A more positive flap setting decreases pitch and speed. It is recommended to test this behaviour of the flaps during familiarization with the glider.

If the flap control system is jammed, the AS 33 Es is converted into an aircraft with a fixed wing airfoil.

#### **Emergency landing with retracted landing gear**

Emergency landings with retracted landing gear are not advised in principle, as the capacity for energy absorption of the fuselage is many times less than that of the sprung landing gear. If the wheel cannot be lowered, the AS 33 Es should be touched down with flaps in position 6 and the airbrakes closed as far as possible, at a shallow angle and without stalling onto the ground. Preferably use grass-strips for landing.

#### **Groundloops**

If the aircraft threatens to roll out beyond the intended landing area, the decision to initiate a controlled ground loop should be made not less than 40 m (130 ft) before reaching the end of the landing area.

- If possible, turn into wind!
- When putting down a wing, at the same time push the stick forward and apply opposite rudder!

### Emergency landing on water

A landing on water with a composite glider with wheel retracted has been experimentally tried out. The experience gained on that occasion suggests that the aircraft will not skim on the water surface, but that the whole cockpit area will be pressed under the surface. If the depth of the water is less than 2m (6,5ft), the pilot is in greatest danger. Therefore, touching down on water is recommended **only with extended landing gear**, and **only** as the very last resort.

### Flying with defective water ballast drainage

The water ballast dump valve operation ensures that the corresponding tanks in both wings are drained at the same time when water ballast is jettisoned. In case of a failure, the control system ensures that both valves stop at nearly the same position to avoid asymmetric loading conditions. If the optional ballast tank in the tail fin is installed, this tank is opened simultaneously. This is necessary for reasons of flight characteristics. Because of that, the valves of the inner wing are not opened until the valve of the tail tank is open as intended. The position and movement of every valve can be evaluated by the LED on the control panel anytime (see section 4.5.6)

When jettisoning water ballast in flight, it should be positively observed that the water is draining from both wings.

If the valves do not open as intended, another try can be performed: shut-off the system (switch in middle position) and after that operate the switch for the valves again in the intended direction.

In case the control panel indicates that the valve of one wing is not opened while the valve of the opposite wing is open than both valves have to be closed using the appropriate switch at the control panel. The same applies when optical control from the cockpit cannot ensure that both sides have opened correctly. A landing at a higher landing weight is to be preferred compared to a landing with an uneven load.



If a wing drain valve does not close, dump all water ballast.

If a failure of the valves should cause asymmetric loads, the flight should be terminated with extreme care, maintaining an adequate margin above stalling speed as incipient or full spins with asymmetric ballast load are not permissible. Special care should be taken to avoid turning and slipping in the direction of the heavier wing.

#### **Defective airbrake control circuit**

If a sudden strong change of flight course happens, the pilot should immediately visually check whether the airbrakes have extended on both wings as this asymmetry may have been caused by an airbrake extended on one wing only. This problem could occur due a defect in the airbrake control circuit and cannot be compensated by rudder deflection. If the airbrake has extended on one wing only, the other airbrake must immediately be extended so far that the aircraft will regain straight and level flight and the airbrake lever must be held in this position.

Depending on the flight altitude immediately initiate an out-landing.

#### **Lightning strike or assumed lightning strike**

Select an airspeed within the green range of the airspeed indicator. Check whether all control surfaces are operational and work correctly. However, the airbrakes should only be tested near a suitable landing area. Should structural damage be anticipated, immediately look for a suitable landing area.

#### **CAUTION**

*Electrical systems are likely to be affected after a lightning strike or they might even fail totally.*

### 3.10 Other emergencies in powered flight

- Intentionally left blank -

## Section 4

- 4 Normal procedures
  - 4.1 Introduction
  - 4.2 Rigging and de-rigging
  - 4.3 Daily inspection
  - 4.4 Pre-flight inspection
  - 4.5 Normal procedures and recommended speeds
    - 4.5.1 Operation of the power-plant
    - 4.5.2 Winch launch
    - 4.5.3 Aero tow
    - 4.5.4 Flight
    - 4.5.5 Approach
    - 4.5.6 Landing
    - 4.5.7 Flight with water ballast
    - 4.5.8 High altitude flight
    - 4.5.9 Flight in rain
    - 4.5.10 Aerobatics
    - 4.5.11 Operation with power-plant removed

## 4 Normal procedures

### 4.1 Introduction

Section 4 provides checklists and procedures for the conduct of normal, daily, operations. Normal procedures associated with optional systems can be found in Section 9.

### 4.2 Rigging and de-rigging

**To rig:** The AS 33 Es can be rigged without use of rigging aids by three people, or by two people when a fuselage cradle and a wing stand are used.

1. Clean and lubricate all pins, bushings and control connections.
2. Support fuselage and keep upright. If the wheel is lowered, check that the landing gear is securely locked down.
3. Set the flap lever to flap setting 1 or 2, push the airbrake lever forward and centre the stick.

#### **WARNING**

*When the flap lever is in position L for landing the automatic flap control connection may fail to engage properly if the flap / aileron deflects upward at the wing. Missrigging is easily detected in pre-flight checks as the flap lever is blocked and a free movement of the control system is not possible.*

4. Begin with the right inner wing and insert its spar fork into the fuselage. If available, support the wing with a wing stand. While rigging, unlock the airbrake over-centre lock in the wing with the special tool (AS-P/N 99.000.8872, the grey, metal lever).



**CAUTION**

*At the wing root, there is a drain hole of the water tank in front of the forward lift pin bushing. This hole has to be closed with the matching bolt (AS-P/N 290.76.0018).*

**NOTE**

*The wing stand must not obstruct the movement of the flap!*

5. Insert left wing spar root and line up the main pin bushings. Insert and lock main pins. Only now - and not before - may the wing weight be relaxed. If the aircraft is still supported in a fuselage cradle, it is recommended that the landing gear should be extended at this stage and locked. Complete rigging with the aircraft standing on its main wheel. Use wing stand for an easy assembly of the outer wings!
6. Screw the provided tool (AS-P/N 99.000.4663, the red, T-shaped handle) into the hole at the outer end of the inner wing leading edge. Unlock and pull the plug pin. Align the outer wing and slide its spar stub into the inner wing. Both the lift pins and the ailerons must connect. When the plug pin lines up with its corresponding bushing, push it in to its distinct stop and lock it. Now the outer wing can be relieved and the tool unscrewed.

**CAUTION:**

*To lock the plug pin, turn the top of the tool in the direction to the fuselage*

*To unlock the safety pin, turn the top of the tool in the direction of the wing.*

**CAUTION**

*Check that the safety pins extensions vanish completely under the airfoil contour.*

**CAUTION**

*It goes without saying that only mating wing tips may be rigged.*

**CAUTION**

*At the wing root of the outer wing, there is also a drain hole of the water tank in front of the forward lift pin bushing. This hole has to be closed with the matching bolt (AS-P/N 290.76.0018)*

7. The winglets are installed into their pockets in the wing tips and secured by the self-engaging spring loaded bolt. Adhesive tape seals the gap and secures the winglet additionally.

Screw the cover of the water ballast filling/ventilation opening on the upper wing surface in place and secure it with self-adhesive white tape.

8. Prior to rigging the horizontal tail, check if a trim weight or -battery in the fin compartment is needed, or already installed! After cleaning and lightly lubricating the elevator studs and sockets, the tailplane is pushed onto the fin from the front. Each half-elevator must be guided into the elevator connections. The elastic lip seal covering the elevator gap must be placed on top of the elevator control tongue. Now push the tailplane home until the hexagon socket head bolt at the leading edge will engage its thread. The bolt must be fully and firmly tightened. It is secured by means of a spring ball catch, whose ball must engage in the grooves on the side of the bolt head.
9. Insert the multi probe into the fin up to the stop and secure it with adhesive tape.
10. A considerable performance improvement can be achieved with little effort by taping all gaps at the wing junctions with plastic adhesive tape (on the non-moving parts only).

**NOTE**

*The ventilation ports of the water tanks must be kept open in any case!*

	Ventilation port location
Inner wing water tank	Top of fuselage, about 7 cm (2.75 in) behind the canopy frame
Outer wing water tank	Outer surface of the winglet, nearly at the top
Tail water tank	atop the left side of the vertical tail

The fin-tailplane junctions should also be sealed with tape. The canopy rim must never be taped over, so as not to impair bail-out.

It is recommended that appropriate areas should be thoroughly waxed beforehand, so that the adhesive tape can afterwards be cleanly removed without lifting the paint finish.

11. Refill the fuel tank
12. Now use the Check List (see the following Section 4.3) to carry out the pre-flight check.

**To de-rig:** proceed in the reverse order of rigging starting with the horizontal tail, winglets, wing tips and inner wings. We would add the following suggestions:

1. Drain all water ballast. To properly do so screw off the cover from the wing water tank on the upper wing surface and open the valves. Ensure that all the water has emptied out by putting down alternative wing tips several times. Despite technical provisions, the wing surfaces might suffer from humidity on the long run.

At the wing root there is a drain hole in front of the forward lift pin bushing. Ensure these holes are open, when wings are put in the trailer, so that remaining water can spill out. The same applies for the valves and the openings at the upper wing surface.

2. If a tail water ballast tank is installed, check if water has gathered in front of the rudder or inside the fuselage tail cone. If water is found, check all hose clamps, hoses and valve for leaks.
3. If the tailplane is very firmly located in its rear seating, it will be more easily dismantled by pushing it forwards by the tips.
4. If a battery box according to TN 3 is installed in the baggage compartment, then the battery has to be removed before de-rigging the aircraft. When necessary, also the platform for the clamping lever can be removed.

### 4.3 Daily inspection

Before commencing flying operations, the aircraft must be thoroughly inspected and its controls checked; this also applies to aircraft kept in the hangar, as experience shows them to be vulnerable to hangar-packing damage and vermin.

#### **Daily inspection of the glider**

The following numbers correspond with those in Fig. 4.3 1 "Tour of Inspection".

- (1) - Open canopy and perform visual inspection of the canopy jettison.
  - Check that main pins inserted up to the handle and secured.
  - Check positive control connections - ailerons, flaps and airbrakes - in fuselage/wing intersection as far as visible
  - Check cockpit and control runs for loose objects or components.
  - Check all batteries for firm and proper attachment (one slot in the upper baggage compartment and below the footrest).
  - Check full, free and stress-free operation of all controls. Hold controls firmly at full deflection while loads are applied to control surfaces.
  - Check ventilation opening and pitot tube in fuselage nose.
  - Check condition and operation of towing hook(s). Release control operating freely? Do not forget release checks!
  - Check wheel brake for operation and leaks. With airbrake paddles fully extended the resilient brake pressure from the main brake cylinder should be felt through the brake handle.
  - Check ventilation opening of inner wing water tanks at top of fuselage for cleanliness.
  
- (2) - Check both upper and lower wing surfaces for damage.

- Check the water ballast valves for correct seating.
  - Check that the wing tips are correctly installed: the plug pin extension vanishes under the airfoil contour, and the ailerons are properly connected without loose play.
- (3) - Flaps and aileron:
- Check condition and full and free movement (control surface clearances). The gap between the inboard/outboard edge of the aileron and the fixed wing must have a clearance of min. 1.5 mm (1/16 in). This clearance is necessary to ensure that these surfaces do not foul the wing cut-out edges when deformed under load in flight. Check linkage fairing for clearance. The friction areas of the elastic seals must be cleaned from any dirt!
- Check the cover for the filling and ventilation opening of the water ballast tank on the upper wing surface for proper seating.
  - Are the winglets undamaged and secured? Is the ventilation port of the outer wing water ballast tank unobstructed?
- (4) - Airbrake paddles:
- Check condition and control connections. Do both sides have good over-centre lock? Check both airbrake boxes for loose objects, stones, water etc.
- The seat areas of the airbrake cover plates must be carefully cleaned!
- (5) - Check inflation and condition of tires:
- |                         |  |
|-------------------------|--|
| Main wheel:             | 3.5 bar ± 0.1 bar (50.8 psi ± 1.5 psi) |
| Fixed tail wheel:       | 2.5 bar ± 0.1 bar (35.6 psi ± 1.5 psi) |
| Retractable tail wheel: | 4.0 bar ± 0.1 bar (58.0 psi ± 1.5 psi) |
- Retractable tail wheel: When the tail wheel is free from ground with tail dolly installed check the proper locking over (tail wheel may not be pushed into the fuselage)
- (6) - Check fuselage, especially underside, for damage.

- (7) - Check static ports in the fuselage tail boom for obstructions (moisture?).
- (8) - Check the pressure port in the fin:  
Is the probe properly seated, tight and secured by elastic tape?
- Check tail water ballast tank drain hole and the ventilation hole to be clean (when tank is installed)
- (9) - Check that the tailplane bolt is tight and locked.
- Is a trim weight or battery installed inside the fin compartment? Elevated minimum cockpit load, see mass and balance form, section 6.3.
- (10) - Check that rudder, tailplane and elevator are correctly fitted, and check for damage or excessive play.

**NOTE**

*Finally, check the water ballast system for leaks, after it has been filled.*

These points are briefly repeated on a checklist on the right cockpit side-wall:

**Pre Flight Check**

- Check main pins (secured)
- Check for foreign matter in the cockpit
- Check outer wings and horizontal tail (secured)
- Check controls (positive connections, freedom of movement, play)
- Check for visible damage on towing hooks, landing gear, surface
- Check TEC-Probe mounted and inserted until stop
- Check whether trim ballast or a battery is installed in the fin
- Check pitot and static pressure openings (dry and unobstructed)
- Check tire pressure and wheel brake
- Test tow release
- Check water tank outlets and ventilation openings
- Check mass and balance
- Check fuel content
- Check power-plant as per the manual

Fig. 4.3-1 Tour of Inspection round the aircraft

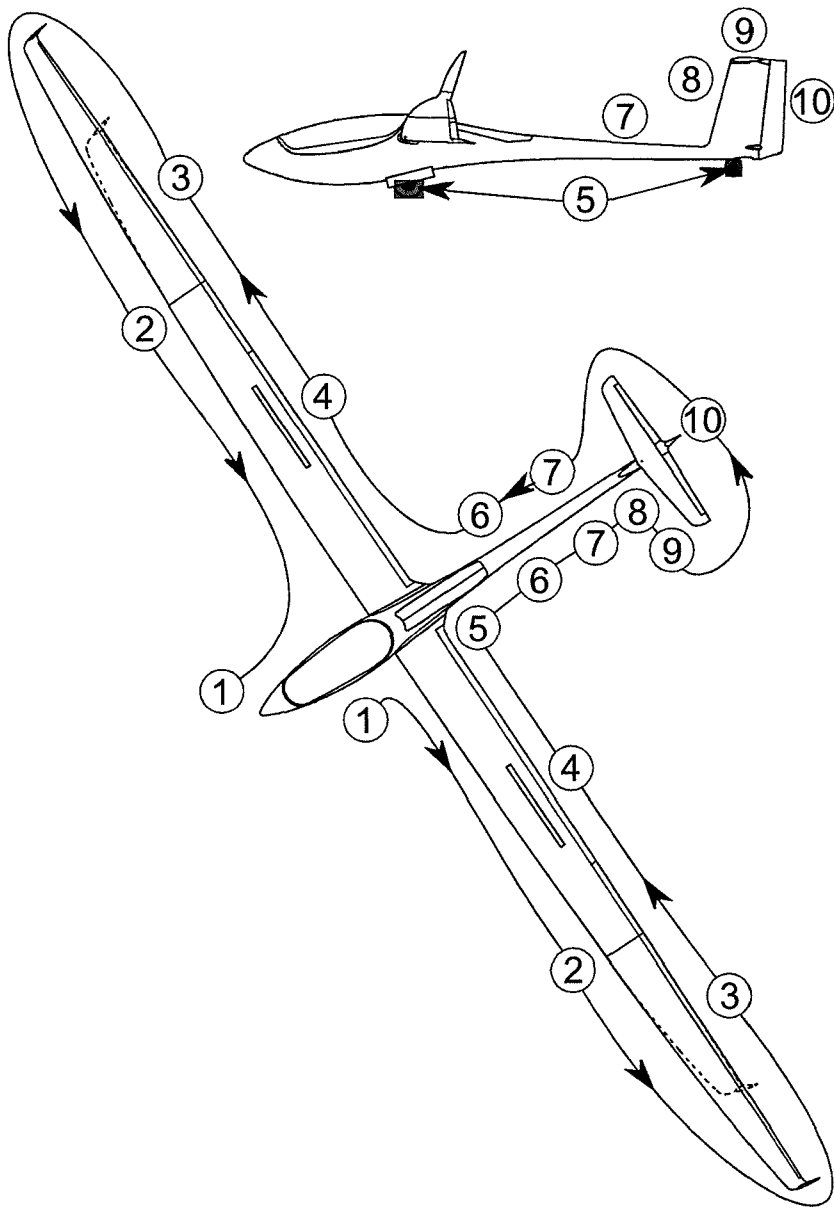

Issue: 01.11.2020 TMO  
Revision:



**Daily inspection of the power-plant**

1. Engine switch to "OFF". Toggle main switch on, check engine and starter battery voltage on the power-plant instrument. Engine and starter battery charged?
2. Extract engine and pay attention to unusual noise and stiffness of operation. Check for full stretch of the toggle lever. The green LED on the power-plant instrument must beam.

**CAUTION**

*If the engine switch is "ON" the ignition is also ON! Therefore it is recommended for all work on the engine to turn the main switch off after the engine was extended and toggle the engine switch back to "OFF".*

3. Check for proper placement and lock of the electric line connectors at the front end of the engine bay.

**CAUTION**

*If the connector is loose, ignition is automatically ON!!*

4. Check condition and function of decompression valves.
5. Check external condition of the engine, the fuel lines and wiring.
6. Retract engine halfway. Check all visible bolted connections (standard stop nuts and thermag-nuts). Are the rubber elements, which hold the engine, intact?
7. Inspect electric lines for signs of chaffing and kinks. Check end switches for correct seating. Toggling the end switches must result in illumination of the appropriate green light at the power-plant instrument. Check for proper seating of the spark plug connectors.
8. Check fuel hoses for visible damages and leakage. There must be no fuel in the impulse line to the membrane pump.

9. Muffler: Check screw connection to the crank case. Check weld seams at the exhaust manifold and silencer for visible cracks (they might be detected by leakage of oil)
10. Visible inspection of engine bay doors. Are the elastic cords and engine support in good condition?
11. Remove the safety pin ("remove before flight"-tag) of the engine switch – only after completion of the daily inspection!

**NOTE**

*Align the propeller vertically before switching on the main switch again to retract (refer also to page 7.22).*

**Daily inspection of the tank system**

1. Press drainer and release any condensation, if present. If possible do this before moving the fuselage. Watch carefully that the drainer afterwards closes tightly again. The drainer is located below the left landing gear bay door.
2. Check fuel tank ventilation opening for dirt. It is located next to the drainer.
3. Check fuel tank content. Check that the power plant instrument shows a fuel content.

**Daily inspection of the propeller**

1. Visual inspection of the propeller mounting. Check proper condition of lock wire. Inspect for damages or cracks at the leading and trailing edge of the propeller (also in the region of the propeller hub)
2. Inspection of leading and trailing edge for damage or cracks. Check the attachment screws are properly secured.

#### 4.4 Pre-flight inspection

Prior to getting on board, check the aircraft loading regarding the total weight and the centre of gravity position. Pay special attention to trim weights installed in the aircraft!

The backrest has to be adjusted properly so that all control elements are easily accessible for the pilot. The headrest has to be adjusted such that the head contact point is at eye level

The following Check List containing the most important points is affixed within easy view of the pilot, below the instrument pod:

#### Pre Take-off Check



- Remove tail dolly
- Fasten parachute
- If applicable connect rip-chord for automatic parachute
- Take a correct seat position
- Fasten seat harness (especially tighten lap straps)
- Check free movement of the controls
- Close airbrakes and lock them
- Set trim in take-off position
- Set flaps in take-off position
- Set altimeter
- Check radio transmission
- Check locking position of the landing gear
- Check wind direction
- Recap the take-off interruption procedure
- Close and lock canopy

## 4.5 Normal procedures and recommended speeds

### 4.5.1 Operation of the power-plant

The power-plant of the AS 33 Es is only intended to help the glider over areas of few or no lift. Self-launching or self-sustaining during other take-off procedures is prohibited! The following paragraphs provides information for the operation of the power-plant during normal flight.

#### Inflight engine start procedure

- (1) Power-plant main switch **ON**
- (2) Airspeed below 140 km/h (76 kts, 87 mph)
- (3) Engine switch  ("ON")
- (4) Green LED  at power-plant instrument illuminated?  
Engine switch **Start** and held up  
(rpms increase to nearly 1500 rpm)
- (5) Release engine switch   
(rpms increase to nearly 3000 rpm)
- (6) Wait until engine starts  
(rpms increase to nearly 4400 rpm)
- (7) Slow down to intended airspeed ( $V_y = 95$  km/h; 51 kts, 60 mph)

#### **CAUTION**

*Always regard the possibility of the engine not starting properly. Therefore, soar in such way, to always be able to reach an out-landing field, despite having an engine. The decision to start the engine must be made at sufficient and safe altitude.*

A minimum safe altitude to extend and start the engine must be maintained. It must be possible to retract the engine again and carry out a normal out-landing if the power-plant malfunctions. A valid value for this minimum safe altitude is about 400 m (1300 ft); however, this depends strongly on pilot ability and geographic factors.

Height loss for extending and starting engine: **usually** about: 15 – 50 m (50 – 170 ft)

Time to extend and start the engine: about 15s



**CAUTION**

*It may take longer if the fuel lines had been completely empty (e.g. if engine was not used for a long time).*

Speed of best climb-rate for a medium wing loading: 95 km/h (51 kts, 60 mph)

Maximum rpm: 5400 rpm

**Remarks:**

- on (4): If the green light does not illuminate, but  flashes red, the LCD display gives more information:  
If it says "SWITCH E" the end switch may be faulty or there was too much resistance for the spindle. Check the position of the engine in the mirror. If it is not fully extended, toggle the engine switch "OFF"  and again "ON"  and maybe help the spindle with a low-g manoeuvre.
- on (7): Opening the decompression is necessary in the beginning to overcome the top dead centre. The decompression valves are automatically controlled by the power-plant instrument. After they are shut again the rotational speed further rises.  
Then the engine noise amplifies, but only a glance on the tachometer or the variometer tells whether the engine already produces power or not. At recommended climb speed (95 km/h; 51 kts; 60 mph) the engine speed should be 4400rpm or higher at sea level and ISA standard conditions.
- on (8): With cold engine and high airspeed, it is possible that the engine revs reach the limit rpm. In this case the power-plant instrument would switch off the ignition for a short time. While this may be bothersome, it is necessary in order to eliminate the over-speed situation.

It is advisable to familiarize oneself with the extending and starting procedures in the first instance within safe reach of an airfield.

Before departing on a cross-country flight it is wise to start the engine for a short time. First, to ascertain its operational readiness and second it may help with the real thing since the fuel lines have already been filled.

If the engine fails to start, check it over as recommended in the Engine Manual.



**WARNING**

Do **NOT** try to start the engine on the ground!

*Usually the engine won't start because of the type of fuelmixture generation. But if it starts for some reason, it directly runs with full throttle! Thus a non-fixed glider is an incalculable danger to life or property.*

*For maintenance ground runs refer to the maintenance manual.*

**Inflight engine stop procedure**

- (1) Ignition OFF  
(by moving engine switch to position "OFF" )
- (2) Reduce airspeed to 100km/h (54 kts, 62 mph)
- (3) Observe in the mirror the correct braking and vertical alignment of the propeller, before it is automatically retracted.
- (4) When green LED  illuminates, turn power-plant main switch **OFF**

**Remarks:**

on (3): The power-plant instrument controls automatically the decompression valves and below 2500 rpm the braking and vertical alignment of the propeller. If flown too fast, the braking torque of the starter motor is not high enough to slow down the engine. Also the vertical propeller alignment is inhibited by flying too fast. If the propeller does not stop in vertical position, in addition to flying slower it is helpful to turn the propeller a half turn further by means of the starter motor.

Issue: 01.11.2020 TMÖ  
Revision:

Height loss during stopping and retracting the power-plant: **usually** about 60 m (200 ft)

Time to stop and retract the power plant: about 30 – 40 s.

**CAUTION**

*Power from the starter battery is needed not only for the engine start but also for the braking and propeller. Therefore a fully charged battery is essential for a safe engine operation. The system has no generator, so the starter battery has to be fully charged before flight.*

**CAUTION**

*The "Start" position of the engine switch has to be locked against accidental operation on the ground by means of a safety pin ("remove before flight" tag)*

**Powered flight**

**CAUTION**

*Medical investigations have shown, how much the interior noise of powered sailplanes with retractable engines can harm the unprotected ear. Therefore always wear ear protection during powered flight. To compensate for this, turn the radio louder.*

The largest cruising range can be achieved with a saw-tooth pattern. That means, to fly under power with the speed of the best climb-rate and glide with retracted engine and the speed of the best glide-ratio.

See section 5.3.6 for performance information.

A detailed description of the power-plant instrument and engine lever is given under section 7.12.

#### 4.5.2 Winch launch

**CAUTION**

*Winch- and autotow-launches must be conducted using the c.g. tow release in front of the landing gear.*

**CAUTION**

*Always start the launch prepared to release. If you cannot keep the wings level, release immediately.*

For winch launch, a weak link of 850 daN  $\pm 10\%$  (1910 lbs, brown) must be used in the launch cable or tow rope. Without water ballast, a weak link of 750 daN  $\pm 10\%$  (1686 lbs, red) may also be used (Weak link colours refer to the colour scheme of the Tost company).

For winch-launching flap setting 5 is recommended. Without water ballast or with low flight experience, flap setting N may also be used. This flap setting is also recommended for aft C.G-position. The trim should be set half-way nose-heavy.

	Recommended	Maximum
Winch-launch airspeed	110 – 130 km/h	140 km/h
	60 – 70 kts	75.5 kts
	68 – 80 mph	86 mph

Maximum acceptable crosswind component is 25 km/h (13.5 kts).

During take-off run, rudder and aileron immediately respond, such that it is possible to maintain the wings at zero bank. With the trimmer adjusted as mentioned above, the AS 33 Es will assume in flap setting 5 a gentle climb attitude after take-off. With flap setting N the gentle climb must be initiated by slightly pulling the stick after lift-off. Nevertheless every winch launch is different and the pilot must be prepared to correct the flight attitude immediately. After take-off pitch and flight path is controllable right away.

**NOTE**

*Actions necessary after a cable failure are always also subject to wind and airfield circumstances. Apart from this, after a cable failure in the flat phase of a winch launch the pilot must immediately push, and establish of a stabilized flight attitude before further actions.*

Issue: 01.11.2020 TMÖ  
Revision:



Above a minimum safe altitude the climb angle should be increased by applying backpressure on the stick.

**CAUTION**

*After a cable failure in the steep part of the winch launch the stick must be immediately and fully pushed forward ("1<sup>st</sup> push stick, 2<sup>nd</sup> release tow hook, 3<sup>rd</sup> consider situation"). Achievement of a safe airspeed can only be learned from the airspeed indicator, not from the pitch attitude.*

**NOTE**

*The landing gear may **not** be retracted during the launch.*

**CAUTION**

*Winch launches with water ballast are only recommended with strong winches. The winch driver must be informed of the total take-off mass.*

**CAUTION**

*Before Take-Off, check seating position and that controls are within reach. The seating position, especially when using cushions, must preclude the possibility of sliding backwards during initial acceleration or steep climb. To do so bring the back rest in the most upright position which is comfortable in order to provide the shoulder straps holding the pilot down in the seat.*

**WARNING**

*We expressly warn against attempting any launch by an under-powered winch in a tail wind!!*

**NOTE**

*Naturally, the engine has to be retracted during winch launch.*

### 4.5.3 Aero tow

**CAUTION**

*The sailplane is only certificated for aero tow operation when the forward tow release is used.*

For aero tows, flap setting 5 or 6 is recommended. The trim should be set half-way nose-heavy. The minimum length of the tow-rope is 40 m (130 ft). A length of 40 m to 60 m (130 to 200 ft) is recommended. A textile rope must be used.

Experienced pilots start their take-off run in flap setting 2. This flap setting offers better lateral control. During ground run the flap setting is steadily increased to 5 or, for short take-off runs or when carrying much water ballast, to setting 6. For the remaining tow, flap setting 5 is selected in safe height. When the aircraft is flown with high wing loading the complete tow can also be performed in flap setting 6.

**NOTE**

*Before start, inform the tug pilot of the recommended towing speed.*

Wing loading	Recommended Towing Speed	
35 kg/m <sup>2</sup> 7.17 lbs/ft <sup>2</sup>	115 km/h 62.0 kts	71.5 mph
45 kg/m <sup>2</sup> 9.22 lbs/ft <sup>2</sup>	120 km/h 64.8 kts	74.6 mph
55 kg/m <sup>2</sup> 11.26 lbs/ft <sup>2</sup>	135 km/h 72.9 kts	84.9 mph

Maximum acceptable crosswind component: 25 km/h = 13.5 kts.

**NOTE**

*The propulsion-system of the AS 33 Es is not suitable to improve the take-off performance of an aero tow, because it has not the necessary level of dependability.*

#### 4.5.4 Flight

**CAUTION**

*Flights in conditions conducive to lightning strikes must be avoided as these are not covered in approvals according to CS22!*

**Flaps**

Flap control allows better adaptation of the aircraft to changing flight attitudes. See diagram in section 5.3.3 for correct flap setting.

Flap settings 1 through 4 are straight flight settings. Setting 1 is for high speed flight, setting 2 is mostly used between thermals. In flap setting 2 the lower wing surface contour is flush and the low drag laminar boundary layer can pass the hinge line to the turbulator on the flap and aileron. Flap settings 3 is intended for moderate fast flight between lifts. Flap setting 4 achieves low drag for slower glide with best L/D.

Flap setting N achieves the minimum rate of descent during horizontal flight. For circling flights that flap setting N should be used with highly contaminated or wet wings instead of the normal circling flap settings.

Flap settings 5 and 6 are purely for use while circling. Flap setting 5 is designed for centring into thermals and circling in turbulent lift. Flap setting 6 should be selected when the conditions warrant strong and tight lift in the core of a thermal.

Because the flap setting directly influences the amount of lift generated over the whole of the wing, a sudden, jerky operation of the flaps will cause a sudden drop or climb; therefore, care should be exercised in this respect, especially when flying close to the ground or circling near other sailplanes.

### Low speed flight, stalls and spins

The AS 33 Es behaves normally in slow and stalled flight. In all C.G. positions, reduced control forces together with flow separations at the fuselage coinciding with a light shaking of the stick will give warning of an impending stall. Approaching stall, the glider can be brought back to a normal flight attitude any time by releasing stick back pressure.

When stalling, the glider may drop a wing. This reaction is more pronounced with more rearward C.G.-positions and more positive flap settings. In positive flap settings and rear C.G. positions, loss of height may be up to 70 m (230 ft) and pitch below horizon may be up to 50°. In case of a stall with airbrakes extended the loss of height depends on how fast airbrakes are retracted. Normally a loss of height with airbrakes extended can be up to 20 m (65 ft).

At the foremost C.G. position, the stall characteristics become very gentle, as the limited elevator deflection will no longer allow maximum angles of attack to be reached. At this C.G. position, only a gentle stall warning will be experienced, but large aileron deflections can be applied without dropping a wing.

With the engine extended, but stopped or wind-milling, there is, but less manifest, a stall warning – because there is already some turbulence in the wake of the engine. With the engine running a strong stall warning comes from the engine, which is running rough at low rpms.

When circling, the stalling speed will increase compared to that in straight flight. As a general guideline, you should expect the stalling speed to increase by 10 % at about 30° bank, and by 20 % at about 45 ° bank. For details on that see section 5.2.2.

The AS 33 Es behaves well in circling flight. Approaching stall with a bank angle of 45° usually leads into a stable sideslip. But if it happens that a wing drops, it may be more drastic than in straight flight (at least with rearmost C.G. position, flap setting 5 or 6). Before that, there is a significant stall warning.

Violent applications of rudder and/or aileron would result in a spiral dive, spinning or side slipping, depending on C.G. position and control deflection.

With the engine extended, but stopped or wind-milling, the airspeed approaches stall speed quicker than in clean configuration, due to the increased drag. In straight flight as well as in circling flight, the glider can be controlled with the stick in the rearmost position for some time, but will drop a wing due to a gust or control deflection. In rearmost c.g. positions, with flap settings 5, 6 or L, which have already created more drag, and the engine extended (stopped or wind-milling), spinning might not be avoidable in such a case.

More specifically, the following would apply:

C.G. Position	Aileron neutral or in direction of ruder	Rudder & Aileron Crossed
Rearmost or middle	steady spin with varying pitch attitude	Spin including side slip
Forward (first thirds)	Spiral dive or short transient spin	side slip

In all flap settings, the glider behaves quite similar while spinning, whereby the spin behaviour is more docile in negative flap settings. Without water ballast, loss of altitude between initiation of recovery and horizontal flight may be 250 m (820 ft). Especially with water ballast, the glider quickly accelerates after the autorotation was stopped, therefore it is necessary to pull out of the dive in a timely manner. With water ballast a loss of altitude of 350 m (1150 ft) may occur.

**NOTE**

*By changing the flap setting to a negative flap setting during easing out the spin the spin recovery is supported and additional turns are minimized.*

**CAUTION**

*When flap setting is 5, 6 or L during spin, change flap to negative setting (e.g. 4) while easing out the dive to ensure not to exceed  $V_{FE}$ .*

**High speed flight (Airspeed indicator in yellow range)**

The following consequences arise from the airworthiness requirements:

**CAUTION**

*Exceed the rough-air speed only in calm air (yellow arc of airspeed indicator).*

**CAUTION**

*Above manoeuvring speed (yellow arc of airspeed indicator), full control deflections must not be applied. At  $V_{NE}$  (red radial line) only one third of the full travel is permissible.*

**CAUTION**

*In the yellow range airbrakes may only be opened under g-loads between  $-1.5$  g and  $+3.5$  g.*

**CAUTION**

*And generally it applies: Do not utilise the otherwise permissible range of control deflections during strong gust loads. Simultaneous full gust loads and manoeuvring loads can exceed the structural strength.*

#### 4.5.5 Approach

Make the decision to land in good time, change to flap setting 5 or 6 and lower the wheel at not less than 150 m (~ 500 ft) above ground.

For the remaining circuit, maintain about 100 km/h (54 kts, 62 mph). The yellow triangle on the ASI scale is valid for maximum weight without water ballast. With remaining water ballast, or in turbulence or strong headwind, increase the approach speed.

The triple-paddle air brakes are normally effective in controlling the glide angle.

**CAUTION**

*Landing flap setting L can be selected on final for steep approaches. You should be certain of easily reaching the boundary of the landing area.*

At airspeeds above 130 km/h (70 kts, 81 mph), the control forces required to engage flap setting L will increase. They are generated by the large deflection of the inboard flaps, which deflect downwards +48°, while the outboard ailerons deflects only +12° down. That's why it is recommended not to change flap setting to L above 130 km/h (70 kts, 81 mph).

This twist increases the sink rate, especially at air speeds between 120 and 130 km/h (65 and 70 kts / 75 and 81 mph). As well, it improves the aileron efficiency.

**NOTE**

*In a strong headwind, use of the landing-flap setting L is NOT recommended, due to the danger of undershooting the landing area!*

If you are not familiar with the use of flaps as a landing aid, you should initially use only flap setting 6 for landing into a headwind.

**NOTE**

*When in danger of undershooting, a reduction of flaps from L to 6 is possible, because due to the flap twist, the stall speeds are in close proximity. But it must only be employed at a safe speed clearly free of any stall warning, above a safe height (at least 40m, 131 ft), and with conscious control of the airspeed. One should have practiced this manoeuvre at greater heights.*

**CAUTION**

*The danger of a sudden drop makes it inadvisable to reduce the flap setting near the ground!*

**Sideslip**

Side slipping with the AS 33 Es is very effective and may therefore also be used for controlling the glide angle.

The sideslip is initiated with airspeed between 90 km/h and 120 km/h IAS (49 to 65 kts) by gently applying aileron control and holding the flight path with the rudder. In a stationary side slip the ASI reading is not usable as it reads between 50 km/h (27 kts) and zero. The correct flying speed is estimated by the pitch attitude. The upper edge of the instrument panel must not rise above a horizon position more than that experienced during thermalling.

The amount of bank and yaw is controllable with the size of the control deflections. Associated negative rudder control force gradients can be overcome by moderate pedal forces or by easing the control stick into a more neutral position. Very high negative rudder forces may be a sign of a too high airspeed

With airbrakes already extended, the slip is more effective, the bank and pitch angle are larger.

If the slip is initiated at too high airspeed and with too dynamic control deflections, the glider may react with violent motions. Entry speed should therefore be max. 140 km/h / 76 kts / 87 mph.



**CAUTION**

*Side slipping should be practiced from time to time at a safe height!*

**CAUTION**

*With a partial but symmetric water ballast load, side slipping is possible!*

**CAUTION**

*With most forward C.G.-positions a pitch down of the aircraft can occur after side slip initiation with negative or neutral flap setting and airbrakes extended which cannot be fully compensated by full pulled control stick. Therefore, side slips must be immediately stopped when recognizing pitch down action.*

**WARNING**

*When an asymmetric water ballast load is suspected or recognized, emergency procedures according to Section 3 are applicable. Side slipping into the direction of the heavier wing must be avoided!*

#### 4.5.6 Landing

In an emergency (e.g. abandoned take-off), structural strength will prove adequate for a landing at maximum take-off mass.

However in normal operation it is strongly recommended that the water ballast is jettisoned before landing, in order to increase the safety margin.

When final approach is flown in flap setting L with some nose-down attitude, remember to round out in time to allow a clean 2-point touch down.

Immediately before touching down, the airbrake setting may be reduced so as to avoid touching down with wheel brake too firmly applied. This is more important with forward C.G.-position.

During the ground run the stick should be held fully back; this gives better directional stability in crosswinds, and prevents the tail from lifting due to hard application of the wheel brake.

The flaps may be left in the landing setting L, because the negative aileron deflection will provide adequate lateral control until the aircraft comes to a stop. If flap setting 6 was used for the landing, it is advisable to engage flap setting 1 after touch down. This will inhibit the sailplane from lifting off again and the aileron effectivity is improved. Also cross-wind sensitivity is reduced with this setting.

When parking the aircraft, engage flap setting 3 to save the plastic sealing strips at the control surface gaps from deformation.

#### **Landing with engine extended**

Approach and landing is preferably carried out with the power-plant retracted. If the electric power supply fails, it is possible to land with the engine extended. For that toggle the engine main switch OFF and switch the ignition off (means the engine switch to "OFF" ). In addition close the fuel valve manually.

The increased sink with extended power-plant should be borne in mind. As a general guideline, a basic sink speed of about 2 m/s (400 ft/min) at 100 km/h (54 kts, 62 mph) may be assumed. It may be possible to do without airbrakes during the landing, and a firmer round-out will be needed.

#### 4.5.7 Flight with water ballast

**NOTE**

*Ballast will increase the stalling speeds and take-off distance. Ensure that the condition of the airfield, the length of take-off run available and the power of the tug, tow-car or winch permits a safe launch.*

The AS 33 Es is equipped with up to five water ballast tanks. Both inner wings contains integrated water tanks with each of about 67 litres (17.7 US-gal.) filling capacity. In addition, both 18m-outer wings have also integrated water tanks which a capacity of 18 litres (4.75 US-gal.) each (The 15m-outer wings have no water tanks integrated). A water tank with 5 litres (1.3 US-gal.) can be optionally integrated in the vertical tail.

The tail water tank is only intended to compensate the nose-heavy moment of the wing water tanks. Therefore, the valve of this tank opens simultaneous with the inner wing water tanks.

**Control**

The AS 33 Es uses an electronic controlled water ballast system. The operating switches are located on a special control panel at the right cockpit wall in front of the landing gear operating lever.

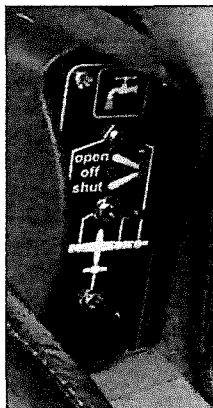

The control panel is equipped with three switches and five LED elements.

The upper switch operates the valves of the outer wings; the middle switch operates the valves of the inner wings and the lower switch operates the tail water tank valve.

Every LED is directly allocated to one of the five water tanks and indicates the position of the corresponding valve. The outer LED correspond to the tanks in the 18m-outer wings while the inner LED are allocated to the tanks in the inner wing. The lowest LED is valid for the tail tank

For all three switches the following applies:



UP: Valve is being opened / is kept open

MIDDLE: Valve is shut down / is stopped

DOWN: Valve is being closed / is kept closed

In case of the wing water tanks one switch operates the valves of the left and right wing at the same time. The valve of the tail water tank can be operated by its own switch independently. However, independent from this switch position the tail tank valve is opened simultaneous with the valves of the inner wing water tanks. If no optional tail water tank is installed the switch has no functionality. The same applies for the switch of the outer wing tanks when the flight is performed with 15m-outer wings.

For the LED elements the following meanings apply:

	off	Permanent	flashing slowly	flashing fast
green	No connection to the corresponding valve	Valve closed	-----	-----
red		Valve opened	Valve at intermediate position without movement	error
green/red alternating		-----	Valve in movement	-----

### Ballast limits

See section 6.3 to determine the maximum permissible amount of water ballast.

Water ballast limitations are listed in section 2.14.

### Filling of water ballast

The wing tanks can be filled through the filling/ventilation openings on the upper wing skin. For filling, the wings must be kept level. The corresponding tank valves have to be closed. Carry out a balancing test to check that the ballast loads are even by levelling the wings.

Issue: 01.11.2020 TMÖ  
Revision:

**WARNING**

*It is expressly prohibited to use pressurised water (mains, immersion pumps etc.) for filling ballast tanks due to possible damage to the wing structure!*

It is recommended to fill from slightly elevated, non-pressurised containers (on wing or car roof etc.). If water under pressure is used, it is essential to interpose an open intermediate vessel (funnel etc.), to ensure that the head-of-pressure cannot rise beyond 1.5 m = 4.9 ft.

**CAUTION**

*Check that the opening cover on the upper wing surface is properly screwed in and secured by tape!*

**CAUTION**

*Having filled the tanks, briefly open valves to check their functionality.*

The tail tank is filled through its drain port (behind the tail wheel). A transparent filling hose is supplied, which can be screwed into the port. For filling the tail water tank the valve must be opened!

The amount of water in the tail tank can be read from the water level in the hose and the level marks on the fin skin. After having filled the tank, close the valve and remove the hose.

**Jettisoning of water ballast**

To jettison water ballast, the switch at the water control panel for the intended water tank is moved to the up position.

Draining the complete outer wing water ballast takes 1.5 minutes. The valve of the tail tank is not operated automatically in that case because the C.G. shifting due to water in the outer wings can be nearly neglected.

Draining the complete inner wing water tanks takes about 4 minutes. The valve of the tail water tank is opened automatically from the control system in that case. The tail tank must empty in less than half the time for safety reasons. Therefore it is not possible to maintain the c.g., when the water load is only partially emptied.

The tail tank water ballast can also be dumped independently from the wing water tanks by using the corresponding switch at the control panel. Draining the complete tail tank takes about 2 minutes.

**WARNING**

*Dumping only the water from tail tank could move the C.G. significant forward. During pre-flight preparation it has to be checked if the C.G. remains within the prescribed limitations when only the tail water is dumped.*

Every time any water is jettisoned, it is most important to check that the water is draining at an equal rate from both corresponding valves (left/right wing)! Asymmetric control deflections may also indicate unequal loading. The colour and behaviour of the LED elements inform about the position of each water tank valve.

Should the wing ballast fail to drain as intended, the valves should be closed immediately (switch down). In case of the inner wing water tanks the switch of the tail water tank should also be moved down to avoid significant shifting of the C.G.-position. Try again to achieve even drainage by operating the valves again or, if icing is suspected, try again after descending into warmer air to achieve a symmetric jettison.

If the valves are to be closed again to retain water in the tanks (partial reduction of wing loading), also check that both valves are really closed. Otherwise jettison all water.

If you do not achieve a symmetric situation after several attempts the situation should be regarded as an emergency, and instructions in Section 3.9 (Other Emergencies) should be followed.

Valves should remain open after the landing to support the drying of the wing tanks!

#### 4.5.8 High altitude flight

With increasing altitude the true airspeed (TAS) will be higher than the indicated airspeed (IAS) due to the reduced air density. However, to be free from flutter the true airspeed is decisive. Therefore, the following limitations of the maximum speed  $V_{NE}$  depending on the altitude results:

Altitude MSL		$V_{NE}$ Indicated Airspeed		
0 m	0 ft	270 km/h	146 kts	168 mph
3000 m	10000 ft	270 km/h	146 kts	168 mph
5000 m	16404 ft	243 km/h	131 kts	151 mph
6000 m	19685 ft	230 km/h	124 kts	143 mph
7000 m	22966 ft	217 km/h	117 kts	135 mph
8000 m	26247 ft	205 km/h	111 kts	127 mph
9000 m	29528 ft	193 km/h	104 kts	120 mph
10000 m	32808 ft	182 km/h	98 kts	113 mph
11000 m	36089 ft	171 km/h	92 kts	106 mph
12000 m	39370 ft	158 km/h	85 kts	98 mph

One of these placard is located near the airspeed indicator:

V <sub>NE</sub> Speed Limit for high altitude		V <sub>NE</sub> Speed Limit for high altitude		V <sub>NE</sub> Speed Limit for high altitude	
Altitude MSL [ft]	V <sub>NE</sub> IAS [km/h]	Altitude MSL [ft]	V <sub>NE</sub> IAS [kts]	Altitude MSL [m]	V <sub>NE</sub> IAS [mph]
0 - 3000	270	0 - 10000	146	0 - 10000	168
< 5000	243	< 15000	135	< 15000	155
< 7000	217	< 20000	124	< 20000	143
< 9000	193	< 25000	114	< 25000	131
< 11000	171	< 30000	104	< 30000	120
< 12000	158	< 40000	84	< 40000	97

The units of measurements used to indicate airspeed on placards must be the same as those used on the indicator!

**WARNING**

*Flights in icing conditions are not advised, especially when the aircraft is wet before climbing through the icing level. Experience suggests that drops of moisture on the surface will be blown back, lodge in the control gaps, and dry comparatively slowly there.*

*This may cause the controls to become stiff to operate, or in extreme cases, jammed. A single climb through icing level with a previously dry aircraft, on the other hand, is not likely to impair the use of the controls, if icing-up of wing and tail leading edges occurs.*

**WARNING**

*When carrying water ballast, avoid flying above icing level due to the danger of iced-up outlet valves, or in extreme cases bursting of wings due to ice formation.*

*Water ballast must therefore be dumped, before entering altitudes with lower temperatures than 3°C (37°F).*



#### 4.5.9 Flight in rain

Rain drops, frost and ice impair the aerodynamic qualities and also alter the flying behaviour. Therefore in such conditions, the quoted minimum speeds for straight and circling flight should be increased by approx. 10 km/h = 5.5 kts. Air speeds should not be allowed to drop below these values.

**CAUTION**

*Rain drops should be removed from a wet aircraft before take-off.*

Do not fly into icing conditions with a wet aircraft. In this context, see also Section 4.5.8 above.

The positive flap setting 5, 6 and L produce significant increased drag with a wet wing. Therefore flap setting N is recommended to use during circling flight with wet or highly contaminated wing.

#### 4.5.10 Aerobatics

Aerobatics are not approved!

#### 4.5.11 Operation with power-plant removed

The AS 33 Es may be operated as a normal sailplane when the power-plant is removed. However, the procedures for the removal and the reinstallation of the power-plant as per section 2.3.4 of the maintenance manual are to be observed.

**NOTE**

*It is recommended to consult the certifying staff (person signing out the reinstallation and the revised loading chart) prior to the removal of the power plant.*

(

(

## Section 5

### 5 Performance

#### 5.1 Introduction

#### 5.2 Approved data

##### 5.2.1 Airspeed indicator system calibration

##### 5.2.2 Stall speeds

##### 5.2.3 Take-off performance

##### 5.2.4 Demonstrated crosswind performance

#### 5.3 Non-approved further information

##### 5.3.1 Flight polar – level flight

##### 5.3.2 Flight polar – circling flight

##### 5.3.3 Flap setting ranges

##### 5.3.4 Influence of c.g.-position

##### 5.3.5 Diagram for approved c.g.-limits

##### 5.3.6 Performance with engine running

##### 5.3.7 Noise data

## 5 Performance

### 5.1 Introduction

This section provides approved data for airspeed calibration and stall speeds as well as non-approved further information.

### 5.2 Approved data

#### 5.2.1 Airspeed indicator system calibration

The following Fig. 5.2-1 shows the indication error of the AS 33 Es pressure system. The ASI will only show a minimal indication error above an indicated airspeed of 90 km/h (48.5 kts, 56 mph). The deviations are within 3 km/h (2 kts, 2 mph). From 120 km/h (64.8 kts, 74.5 mph) the deviation of the ASI can be neglected.

#### **CAUTION**

*The ASI must take its pitot pressure from the pitot-tube in the fuselage nose, and its static pressure from the static ports in the fuselage tail boom.*

Fig. 5.2-1: Deviation in airspeed indication

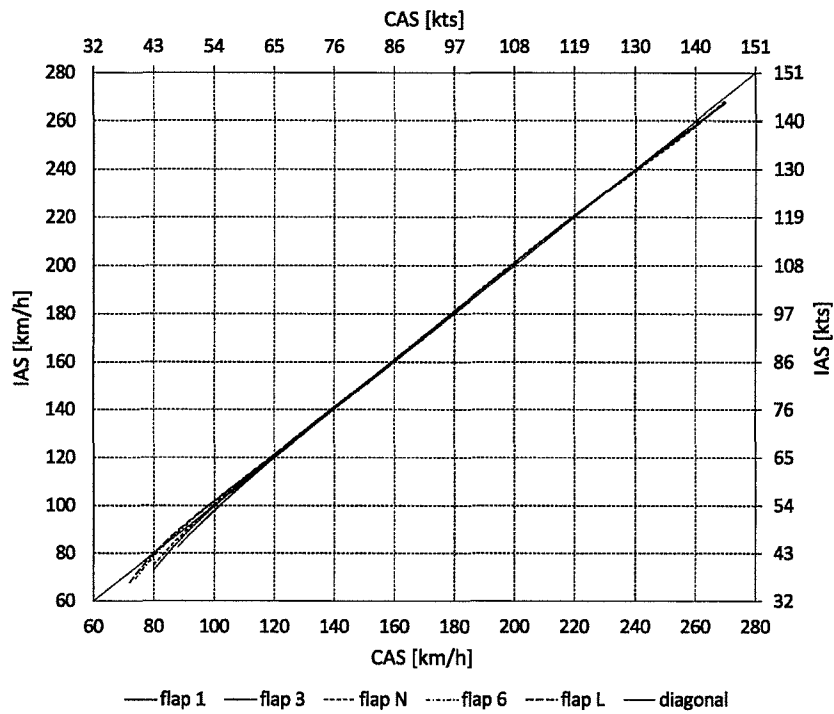

IAS = Indicated Air-Speed  
 CAS = Calibrated Air-Speed

## 5.2.2 Stall speeds

Stall Speeds in km/h and kts Indicated Air Speed.

<b>18 m / 59 ft</b>			
Flap setting	All up weight		
	400 kg / 882 lbs	500 kg / 1102 lbs	600 kg / 1323 lbs
1	70 km/h / 37.8 kts	78 km/h / 42.1 kts	86 km/h / 46.4 kts
2	69 km/h / 37.3 kts	77 km/h / 41.6 kts	85 km/h / 45.9 kts
3	67 km/h / 36.2 kts	75 km/h / 40.5 kts	82 km/h / 44.3 kts
4	66 km/h / 35.6 kts	74 km/h / 40.0 kts	81 km/h / 43.7 kts
N	64 km/h / 34.6 kts	72 km/h / 38.9 kts	79 km/h / 42.7 kts
5	62 km/h / 33.5 kts	69 km/h / 37.3 kts	75 km/h / 40.5 kts
6	61 km/h / 32.9 kts	68 km/h / 36.7 kts	74 km/h / 40.0 kts
L	61 km/h / 32.9 kts	68 km/h / 36.7 kts	74 km/h / 40.0 kts
L + air-brake	67 km/h / 36.2 kts	75 km/h / 40.5 kts	82 km/h / 44.3 kts

<b>15 m / 49 ft</b>			
Flap setting	All up weight		
	400 kg / 882 lbs	500 kg / 1102 lbs	550 kg / 1212 lbs
1	77 km/h / 41.6 kts	86 km/h / 46.4 kts	96 km/h / 51.8 kts
2	76 km/h / 41.1 kts	85 km/h / 45.9 kts	94 km/h / 50.8 kts
3	75 km/h / 40.5 kts	83 km/h / 44.8 kts	94 km/h / 50.8 kts
4	73 km/h / 39.4 kts	82 km/h / 44.3 kts	92 km/h / 49.7 kts
N	71 km/h / 38.3 kts	80 km/h / 43.2 kts	91 km/h / 49.1 kts
5	69 km/h / 37.3 kts	78 km/h / 42.1 kts	88 km/h / 47.5 kts
6	69 km/h / 37.3 kts	78 km/h / 42.1 kts	88 km/h / 47.5 kts
L	65 km/h / 35.1 kts	73 km/h / 39.4 kts	82 km/h / 44.3 kts
L + air-brake	71 km/h / 38.3 kts	80 km/h / 43.2 kts	90 km/h / 48.6 kts

Issue: 01.11.2020 TMO  
Revision:

## 5.4

The quoted speeds are valid for an aerodynamically clean glider.

Stall warning by buffeting will commence at about 5-10% above the indicated stall speeds.

Extension of air brakes increases the indicated stall speed in straight flight by 5 – 10 km/h (3 - 5 kts). The extension of the landing gear has no influence.

### Stall speeds in circling flight

In circling flight the stall speeds increase due to the higher load factors.

Bank angle	0°	30°	45°	60°	75°
Stall speed in turns compared to straight flight	100%	107%	119%	141%	200%

### Loss of altitude and pitch below horizon

Loss of altitude until regaining level flight after stall from straight or circling flight depends largely on:

- the total mass and c.g. position
- how quickly the pilot reacts
- the flap setting (more loss of height in more positive settings)
- turbulence of the air (lower stall speed achievable in still air, but more drastic wing drop)

Loss of altitude from straight flight: up to 70m (229 ft).

Loss of altitude from straight flight with airbrakes extended: up to 100m (330ft).

The cockpit nose may pitch 10° to 50° below the horizon.

Height loss from circling flight: up to 100 m (about 330 ft).

### 5.2.3 Take-off performance

- Intentionally left blank -

---

Issue: 01.11.2020 TMÖ  
Revision:

**5.6**



- Intentionally left blank -

#### 5.2.4 Demonstrated crosswind performance

Winch Launch: 25 km/h (13.5 kts / 15.5 mph)

Aerotow: 25 km/h (13.5 kts / 15.5 mph)

Landing: 25 km/h (13.5 kts / 15.5 mph)

5.3 Non-approved further information

5.3.1 Flight polar – level flight

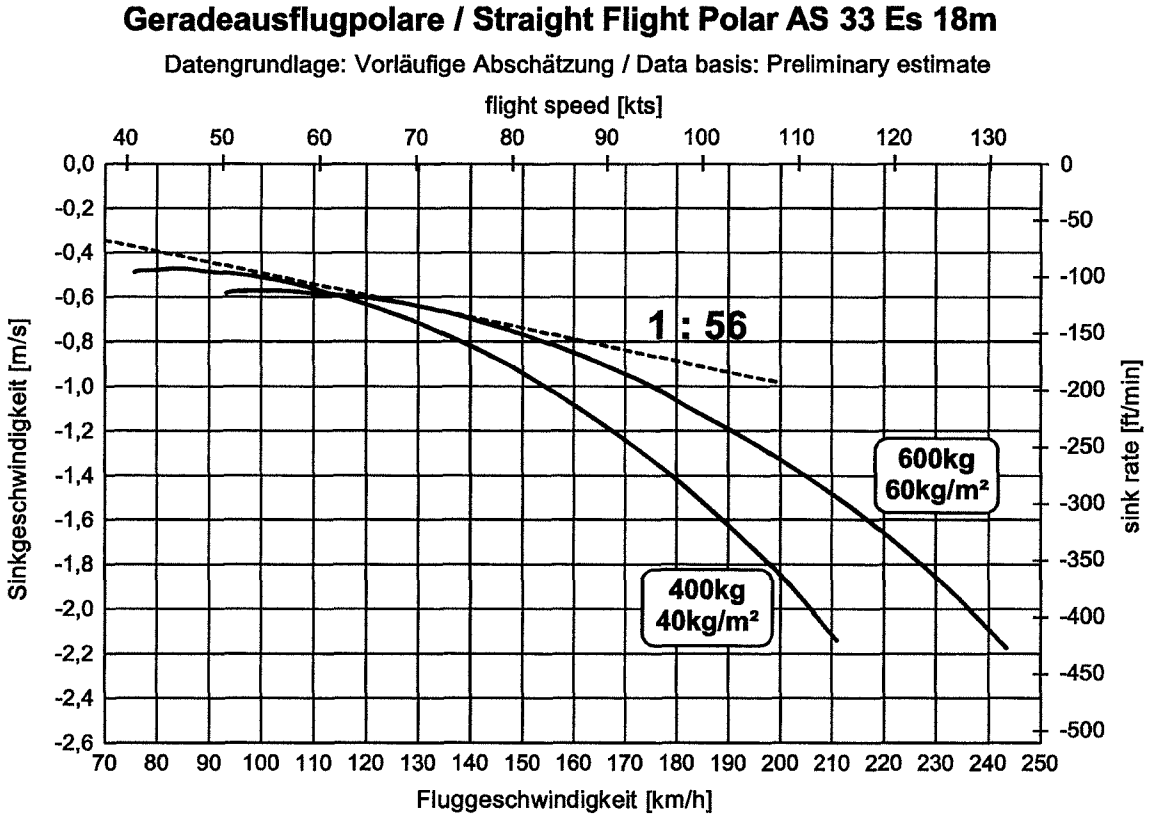

Issue: 01.11.2020 TMO  
 Revision:

### Geradeausflugpolare / Straight Flight Polar AS 33 Es 15m

Datengrundlage: Vorläufige Abschätzung / Data basis: Preliminary estimate

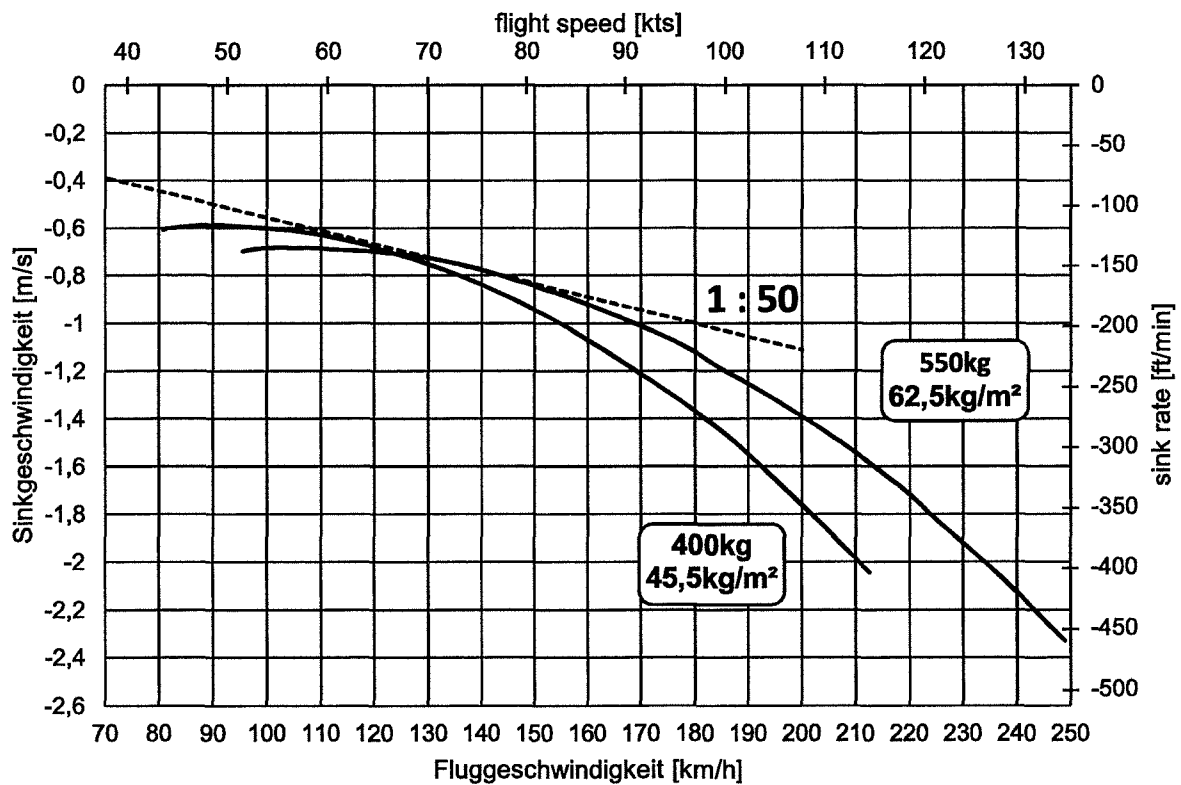

### 5.3.2 Flight polar – circling flight

*Not yet available!*

5.3.3 Flap setting ranges

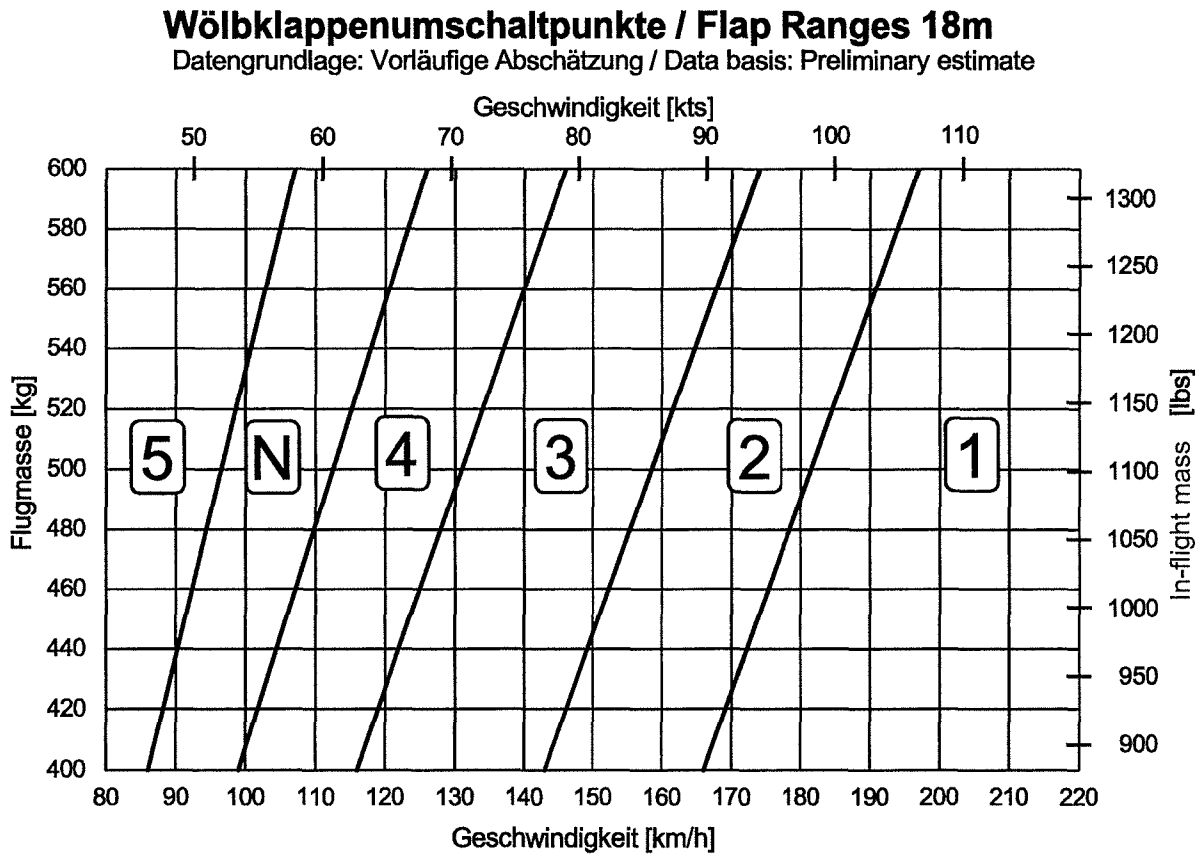

### Wölbklappenumschaltpunkte / Flap Ranges 15m

Datengrundlage: Vorläufige Abschätzung / Data basis: Preliminary estimate

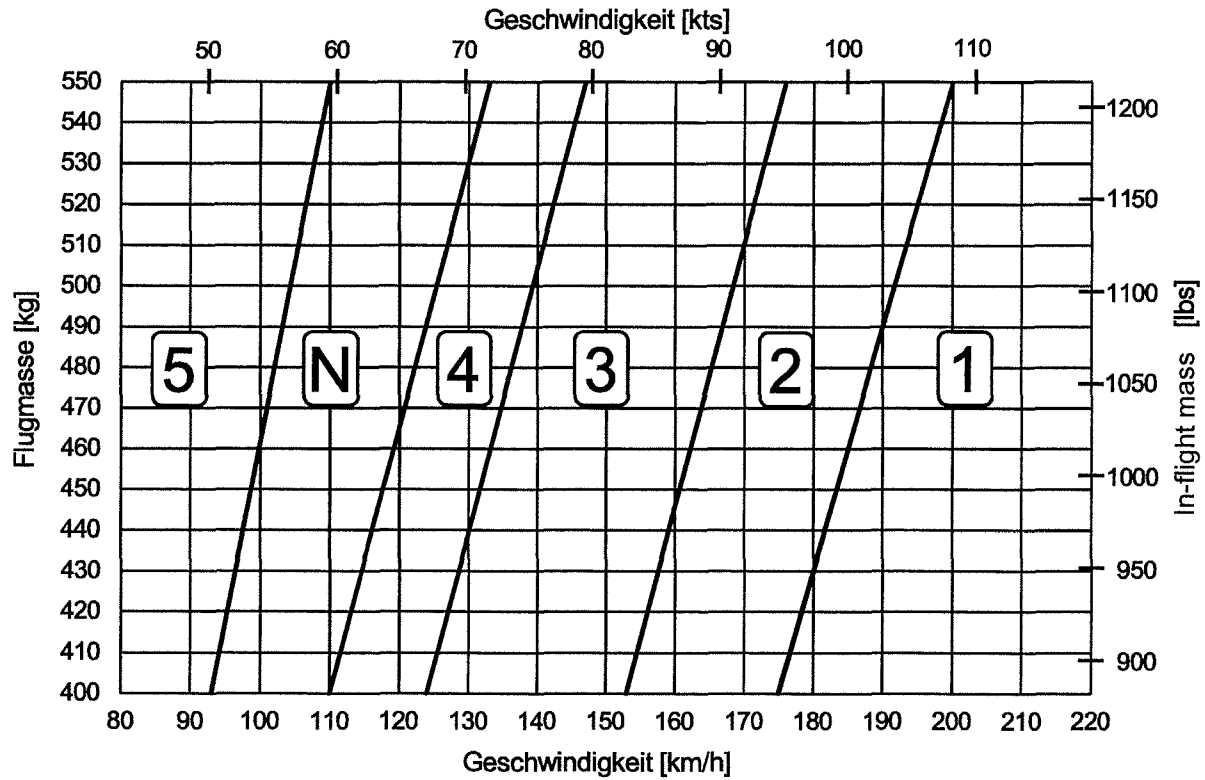

The above diagrams describe the speed ranges of the various flap settings in straight flight, depending on the mass.

Flap Setting	L	6	5	N	4	3	2	1
Flap deflection	48°/12°	25°	20°	12°	6°	3°	0°	-2°
Description	Landing	Circling	Circling	Neutral	Best L/D	Gliding	Gliding	Fast speed

Flap setting 5 has a lower sink rate than flap setting 6. However, flap setting 6 provides more lift and lower minimum speeds so that narrow thermals can be better used

#### 5.3.4 Influence of c.g.-position

To achieve the best gliding performance, the horizontal tail surface must not produce up- or downward lift. In addition, the required elevator deflections to trim any airspeed should be reduced to a minimum.

This optimum cannot be realized over the whole range of airspeeds. Therefore the best choice depends on the proportion of time spent in circling and in gliding.

In general, the optimum c.g. position may vary around 290 – 300 mm (11.41 in – 11.81 in) behind r.p. In the special case of flights with a large share of time in flap settings 1 and 2 (e.g. wave flights), a c.g. position of 260 mm (10.23 in) may be more adequate.

As a matter of principle, the c.g. position has a great influence on longitudinal stability. In forward c.g. positions, control deflections and hand force gradients are larger. Thus it is advisable for inexperienced, light pilots to add more lead on the (optional) attachment in front of the pedals than necessary to comply with the minimum cockpit load.



5.3.5 Diagram for approved c.g.-limits

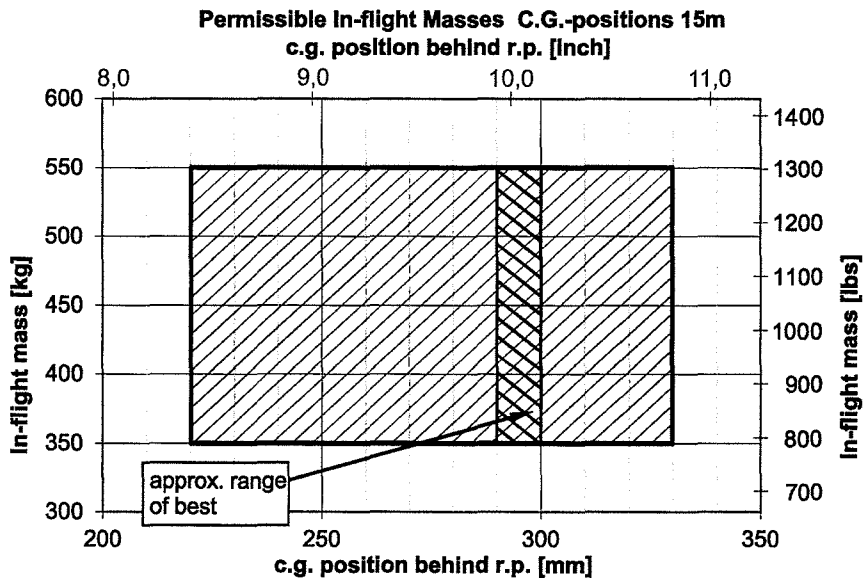
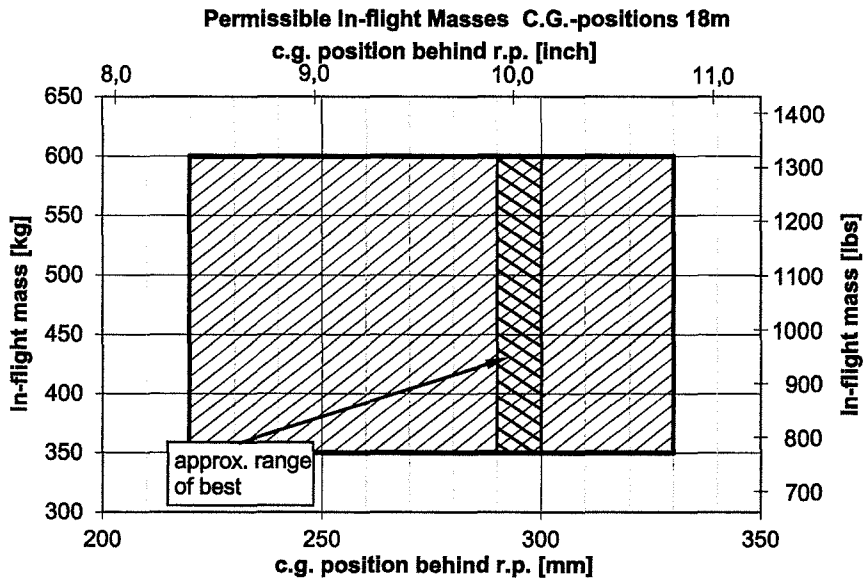

Issue: 01.11.2020 TMO  
Revision:

The permitted c.g.-range is maintained, when

- the maximum weight of non-lifting parts is observed
- the c.g. of the dry glider is within the permissible range (see Mass and Balance Form, section 6.2)
- the aircraft is loaded in accordance with section 6

### 5.3.6 Performance with engine running

The performance depends strongly upon altitude, temperature and wing loading. The following values refer to standard atmosphere and sea level.

#### Climb rate

Without water ballast a best climb rate of 1.2 m/s (236 ft/min) can be achieved at an airspeed of  $V_Y = 95$  km/h (51 kts, 59 mph). Flap setting according to section 5.3.3.

#### Cruise

The maximum speed for level flight without water ballast at sea level is  $V_H = 120$  km/h (64 kts, 75 mph). The airspeed for horizontal flight decreases with height.

An altitude of 2800m (9200 ft) MSL (standard atmosphere) can be maintained with maximum wing loading and an airspeed of  $V_H = V_Y = 95$  km/h (51 kts, 59 mph).

#### Flight with maximum wing loading

With full wing loading, the climb rate is considerable lower, therefore it is recommended to dump the water ballast.

### Range

A full fuselage tank contains sufficient fuel for at least 35 min of powered flight.

The largest range is possible in a saw tooth flight, climbing with the speed of the best climb-rate and gliding with retracted engine and the speed of the best L/D.

Regarding density altitude, actual climb-rate and height above ground it is favourable to use the engine in several climb phases at medium altitudes.

From this results a **theoretical** range of:

In powered flight: 55 km / 29.7 Nm

Gains altitude: 2500 m (8200 ft)

Average altitude loss for 3x starting and retracting: 300 m (1000 ft)

Gliding with the speed of best L/D: 125 km / 67.5 Nm (18 m)

110 km / 59.4 Nm (15 m)

In summary: **180 km / 97.2 Nm (18 m)**

**165 km / 89.1 Nm (15 m)**

With the optional fuel tank extension (resulting fuel quantity 11 litres) the time of powered flight can be increased to about 55 minutes. This leads to a theoretical range of 285 km (153.9 Nm) with 18 m span respectively 230 km (124.2 Nm) with 15 m span.

### 5.3.7 Noise data

According Chapter 10 of ICAO Annex 16 sailplanes with self-sustaining engines were not affected by noise limit values. Therefore, no noise measurement was performed for the AS 33 Es.

(

(

## **Section 6**

- 6 Mass (weight) and balance, C.G. position
  - 6.1 Introduction
  - 6.2 Mass (weight) and balance form
  - 6.3 Additional masses (weight) in the fuselage
  - 6.4 Water ballast
  - 6.5 Calculation form

## 6 Mass (weight) and balance, C.G. position

### 6.1 Introduction

This section describes the payload range within which the AS 33 Es may be safely operated.

Procedures for weighing the sailplane and the calculation method for establishing the permitted payload range are contained in the applicable AS 33 Es **Maintenance Manual**, Section 6.

A complete list of all equipment installed in the particular sailplane during the last weighing is enclosed in the sailplane records.

During weighing the sailplane the mass and balance is determined for the aircraft in a defined basic configuration. The kind of configuration depends on the fact whether the power-plant is installed or not:

Power-plant installed	Power-plant removed
Aircraft including instruments and equipment according latest equipment list	Aircraft including instruments and equipment according latest equipment list
Backrest and seat cushion	Backrest and seat cushion
Logbook and flight manual	Logbook and flight manual
Starter battery in engine compartment	Avionic battery in upper baggage compartment right-hand
Engine battery below footrest	
Avionic battery below footrest	

It is of vital importance for safe flight not to exceed the limits for the inflight centre of gravity, given in section 2.7.

If the sailplane is operated exactly in accordance with the described configuration the limits are directly observed if the loading limits from section 6.2 were met. If these limits could not be observed or additional masses were carried on-board during flight than these additional masses have to be considered according section 6.3.

## 6.2

When the flight is conducted using water ballast then the loading conditions have to be checked according section 6.4.

Section 6.5 shows a sample form for a detailed calculation of the inflight centre of gravity. This could be used if the c.g. needs to be exactly known for performance reasons. All required lever arms and masses required for this calculation are shown in section 6.2 and 6.3.

#### **Unit conversions**

25.4 mm = 1 in

0.4536 kg = 1 lb

Fuel (average density, standard temperature):

1 L = 0.73 kg = 0.264 US-gal. = 1.61 lbs

## 6.2 Mass (weight) and balance form

The following mass and balance form shows the maximum and minimum load in the pilot seat and the total load in the fuselage. In addition, the empty mass of the aircraft and the empty centre of gravity are shown. All values are valid for the basic configuration as described in section 6.1.

The form does **not** regard additional trim masses like the trim mass in the vertical tail, the trim mass in front of the rudder pedals or other optional batteries. To comply with the requirements for the in-flight c.g. and the maximum loading these values have to be calculated and checked! The same applies for flights with water ballast.

These mass and balance data must be calculated in accordance with the currently valid weighing data. The data and diagrams needed for establishing these are to be found in the AS 33 Es Maintenance Manual, Section 6.

Unless otherwise stated, all values are valid for flights with 18 m span as well as with 15 m span.

This Mass and Balance Form is valid only for the aircraft bearing the Serial No. shown on the title page of this manual!

---

Issue: 01.11.2020 TMÖ  
Revision:



## Mass and balance form

Inspectors stamp and signature		
Max. useful load in the fuselage <sup>2)</sup> (15 & 18m)	113	
Permissible pilot mass incl. parachute <sup>2)</sup>	maximal	113
	minimal	76
Empty mass C.G. aft of RP <sup>3)</sup>	18m	512,4
	15m	
Empty mass <sup>2)</sup>	18m	355,7
	15m	
Power-plant installed <sup>1)</sup>	yes	
Date of weighing	08.05.2021	

- 1) Insert YES/NO. Check aircraft configuration for compliance with specification according table shown in section 6.1!
  - 2) For U.S.-registered sailplanes show lbs.
  - 3) For U.S.-registered sailplanes show inches.
- Other countries may use metric units.

Issue: 01.11.2020 TMÖ  
Revision:

### 6.3 Additional masses (weight) in the fuselage

Deviating from the basic configuration the AS 33 Es can be flown with additional masses on board. The following points contains necessary information and data regarding the effect on empty mass and centre of gravity for the different loading items.

#### **CAUTION**

*When the following paragraphs provides "rules of thumb", these calculations leads to conservative results. Exact results can be achieved using the calculations shown in section 6.5 with the lever arms and masses presented. Especially with regards to the gliding performance a detailed calculation is recommended.*

#### **Trim ballast in front of the rudder pedals**

If the pilot is lighter than the minimum load in the cockpit seat prescribed by the weight and balance form (section 6.2), then the weight can be replaced with trim ballast plates fitted in front of the rudder pedals (see section 7.11).

One trim ballast plate has a weight of 1.0 kg (2.2 lbs). Up to eight plates can be installed. The lever arm of the trim ballast plates is  $x = -1700$  mm (-66.93 in).

The effect of the trim ballast plates to the in-flight C.G. can be calculated according the calculation sheet from section 6.5. Alternatively the effect can be estimated by the following ratio:

Per one trim ballast plate installed in front of the rudder pedals, the minimum load in the cockpit seat is reduced by 2.2 kg (4.85 lbs).

The trim ballast plates has to be considered when calculating the total load in the fuselage.

#### **Trim ballast in the vertical fin**

A housing is provided in the upper part of the fin where trim ballast, for instance in the form of a battery, may be fitted.

---

Issue: 01.11.2020 TMO  
Revision:

The maximum permitted trim mass in the vertical fin is limited to 3.6 kg (7.93 lbs). The lever arm of this trim ballast is  $x = 4132$  mm (162.68 in). For all calculations the actual weight of the trim ballast (battery) has to be considered.

Of course, if any trim ballast is mounted in the fin, the minimum cockpit load will be increased! Compliance with the prescribed in-flight C.G. can be checked with the calculation sheet presented in section 6.5 or can be estimated by the following ratio:

Per 1 kg (2.2 lbs) trim weight in the vertical fin, the  
minimum load in the cockpit seat is increased by  
7.5 kg (16.53 lbs).

The trim ballast in the vertical fin has to be considered when calculating the total load in the fuselage.

#### **Batteries under the footrest**

When the power-plant is removed from the AS 33 Es the fuselage can be equipped with two optional batteries below the footrest (see section 7.11). When the power-plant is installed then these two batteries were installed by default and regarded in the weight and balance sheet from section 6.2.

The weight of the installed batteries depends on the type and the manufacturer of the battery. The exact weight of the battery has to be determined before the installation. The lever arm of these batteries is  $x = -1050$  mm (41.34 mm).

Of course, the installation of such batteries decreases the minimum cockpit load. Compliance with the prescribed in-flight C.G. can be checked with the calculation sheet presented in section 6.5 or can be estimated by the following ratio:

Per 1 kg (2.2 lbs) battery weight below the footrest,  
the minimum load in the cockpit seat is decreased by  
1.7 kg (3.74 lbs).

The weight of batteries below the footrest has to be considered when calculating the total load in the fuselage. Check before flight whether batteries are installed by opening the cover at the footrest. See also section 7.10.

**Baggage in the cockpit**

With power-plant installed the pilot can use the baggage compartment behind the head rest. When the power-plant system is removed another baggage compartment left of the main landing gear is available.

The upper compartment is limited to 12 kg (26.4 lbs). The limit for the lower compartment is 5 kg (11 lbs). The baggage has to be considered when calculating the total load in the fuselage. For both compartments the effect from baggage on the in-flight C.G. can be neglected. However, for a detailed calculation according section 6.5 a lever arm of  $x = 150 \text{ mm}$  (5.9 in) can be assumed for the upper compartment. The weight of the baggage in the lower compartment has a lever arm of  $x = 200 \text{ mm}$  (7.87 in).

**Oxygen bottle**

The AS 33 Es can be optionally equipped with an oxygen bottle fixed at a mounting to the right of the main landing gear box (see section 7.11). The exact bottle weight has to be determined prior to installation. The maximum mass of 5.0 kg (11 lbs) must not be exceeded! The effect of the oxygen bottle on the in-flight C.G. can be neglected. However, for a detailed calculation according section 6.5 a lever arm of  $x = 210 \text{ mm}$  (8.27 in) can be assumed.

The weight of the oxygen bottle has to be considered when calculating the total load in the fuselage.

**Fuel**

The effect from fuel on the in-flight C.G. can be nearly neglected (lever arm  $x = 60 \text{ mm}$  (2.36 in)). The weight of the fuel carried on-board has to be considered when calculating the total load in the fuselage. Per one litre of fuel a weight of 0.75 kg (1.65 lbs) can be assumed.

## 6.4 Water ballast

The integrated wing water tanks of the AS 33 Es can hold about 170 liters (44.9 US-gal.) together. This volume is divided into two times 67 liters (16.7 US-gal.) in the two inner wings and two times 18 liters (4.75 US-gal.) in the 18m-outer wings. In addition, the vertical tail contains another water tank with 5 liters (1.32 US-gal.) quantity. This water tank is only intended to compensate the movement of the C.G. from water ballast in the wings.

When flights were performed with water ballast on-board then several limits have to be observed. Compliance with these limits must to be checked prior to the flight:

### 1. Maximum take-off weight

Maximum take-off weight may not be exceeded:

Span	18 m	15 m
Maximum take-off weight	600 [kg]	550 [kg]
- Empty weight (Weight and balance form, section 6.2)	-xxx [kg]	-xxx [kg]
- Additional weight in fuselage (section 6.3)	-xxx [kg]	-xxx [kg]
- Pilot weight including parachute	-xxx [kg]	-xxx [kg]
= max. water load (incl. tail water tank)	xxx [kg]	xxx [kg]

### 2. Maximum weight of non-lifting components

Maximum weight of non-lifting components (300kg / 661 lbs) may not be exceeded:

Total useful load in fuselage Weight and balance form, section 6.2)	xxx [kg]
- Additional weight in fuselage (section 6.3)	-xxx [kg]
- Pilot weight including parachute	-xxx [kg]
= max. water load in tail tank	xxx [kg]

**3. Movement of the C.G.**

The water ballast in the wings moves the centre of gravity forward. To compensate for this movement additional water in the tail tank is required. Due to the geometry of the wings and the filling quantity the effect on the C.G. movement is more present due to water in the inner wings than from water in the outer wings. Therefore, only the water ballast in the inner wings needs to be considered.

The following chart can be used to determine the required filling quantity in the tail water tank. The effect of the water loading on the C.G. depends significantly on the in-flight C.G. which would be present without water ballast. Therefore, this value must be considered! The chart contains lines for forward C.G.-positions ( $x = 220 \text{ mm} / 8.66 \text{ in}$ ), middle C.G.-positions ( $x = 275 \text{ mm} / 10.83 \text{ in}$ ) and rear C.G.-positions ( $x = 330 \text{ mm} / 13.0 \text{ in}$ ). In addition one line for the optimal C.G.-position ( $x \sim 295 \text{ mm} / 11.61 \text{ in}$ ) is presented. If the in-flight C.G.-position is not exactly known, then the line for middle C.G.-positions must be used!

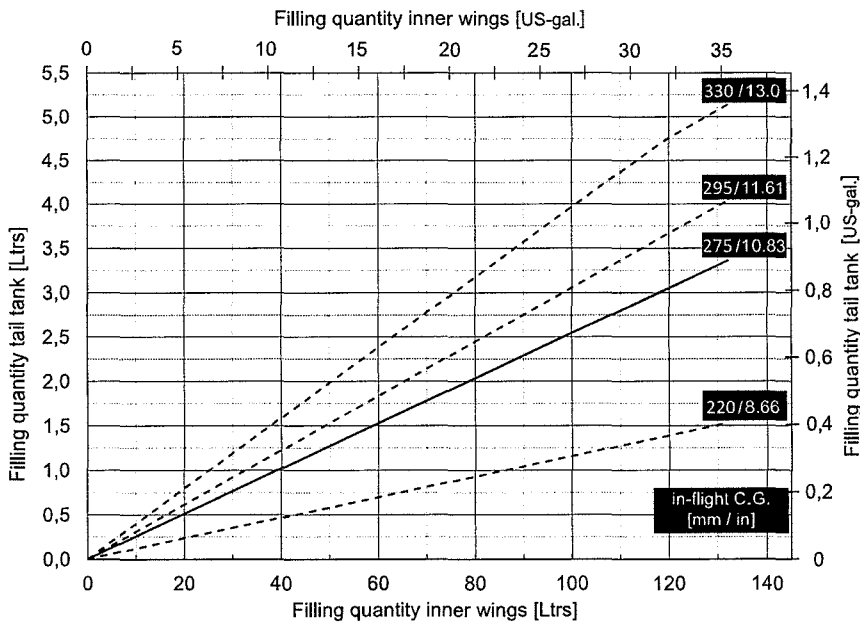

Issue: 01.11.2020 TMÖ  
Revision:

As an alternative to the estimation by the charts shown above the required compensation of the centre of gravity can be performed by calculation. In that case the calculation is done as shown in section 6.5. The following lever arms can be assumed:

- The lever arm of the water ballast at the inner wings is nearly independent from the filling quantity. A value of  $x = 173$  mm (6.81 in) can be assumed.
- The lever arm of the water ballast in the outer wings depends on the filling quantity:

water ballast in outer wings total	lever arm of water ballast in outer wings
10 kg (22.05 lbs)	189 mm (7.44 in)
20 kg (44.1 lbs)	210 mm (8.27 in)
36 kg (79.37 lbs)	246 mm (9.69 in)

- The lever arm of the water ballast tank in the vertical tail is  $x = 4395$  mm (173.03 in).

Description	Quantity	Weight	Lever arm	Moment
Empty weight and C.G.-position of empty aircraft (see page 6.5)		kg ×	mm =	kgmm
Pilot weight and lever arm (see page 6.13)		kg ×	mm =	kgmm
Trim weight or battery in vertical tail		kg ×	+ 4132 mm =	kgmm
Trim weight in front of rudder pedals	<input type="checkbox"/> plates ×	1,0 kg ×	- 1700 mm =	kgmm
Lower baggage compartment (fuel tank removed)		kg ×	+ 200 mm =	kgmm
Upper baggage compartment (behind headrest)		kg ×	+ 150 mm =	kgmm
Fuel quantity (next to landing gear compartment)	<input type="checkbox"/> liters ×	0,75 kg ×	+ 60 mm =	kgmm
O <sub>2</sub> -bottle next to landing gear compartment)		kg ×	+ 210 mm =	kgmm
Batteries under footrest*	<input type="checkbox"/> pcs ×	kg ×	- 1050 mm =	kgmm

sum weight = kg      sum moment = kgmm

sum fuselage loading =  kg

The sum of the fuselage loading has to be lower than the usefuel load in the fuselage!

$$\text{in-flight C.G.} = \frac{\text{sum moment}}{\text{sum weight}}$$

The in-flight C.G. has to be between 220 mm and 330 mm aft of reference point (wing leading edge at fuselage)!

\*Normally installed during weighting. Fill in only if necessary!



For the calculation of the in-flight centre of gravity the lever arm of the pilot in the cockpit must be known. The following reference values can be assumed:

pilot mass	pilot lever arm	
	lower ref.	upper ref.
70 kg	-615 mm	-565 mm
90 kg	-590 mm	-545 mm
115 kg	-550 mm	-530 mm

For an exact value of the pilot lever arm a weighing must be performed with the pilot including parachute on board.

(

(

## Section 7

### 7 Description of the powered sailplane, its systems and equipment

- 7.1 Introduction
- 7.2 Cockpit controls
- 7.3 Instrument panel
- 7.4 Landing gear system
- 7.5 Seat and safety harness
- 7.6 Pitot and static systems
- 7.7 Airbrake system
- 7.8 Baggage compartment
- 7.9 Water ballast system
- 7.10 Electrical system of the avionic
- 7.11 Miscellaneous equipment
- 7.12 Power-plant
- 7.13 Fuel system
- 7.14 Electrical system of the power-plant

## 7 Description of the powered sailplane, its systems and equipment

### 7.1 Introduction

This Section provides description and operation of the sailplane and its systems. Refer to Section 9, Supplements, for details of optional systems and equipment.

A detailed technical description of the glider with layout drawings can be found in the Maintenance Manual.

### 7.2 Cockpit controls

#### Aileron and elevator

Both these controls are operated by means of the control column (or stick). The stick is also fitted with the trim release lever for setting the trim, and with the radio transmit button.

#### Rudder

The rudder pedals are adjustable to suit the length of the pilot's legs.



#### Pedal adjustment

Grey knob in front of the stick

#### To move pedals forward:

Pull knob and push pedals forward with your heels. Release knob and push again to lock in position.

#### To move pedals aft:

Relax pressure on pedals, pull knob back. Then release knob and apply pressure to pedals to lock in position.

**WARNING**

*When the pedals are in their rearmost position large shoes may interfere with the fuselage structure. Check free movement of the rudder control circuit!!*

**Flap control**

The AS 33 Es wing is equipped with two trailing-edge flaps on each wing covering the entire span. In flap settings 1 to 6 both flaps are synchronized. Both flaps also work as ailerons, with the inboard flap making only small deflections, for higher lift in circling flight. (Therefore the inner flap is often referred to as "flap", while the outer flap is called "aileron").

When the landing flap setting L is selected, the inboard flap deflects downwards 48° whereas the aileron only deflects downwards 12°. This increases sink rate, improves the aileron effectiveness, and slightly reduces the stall speed.

The wing flaps and ailerons are equipped with dimpled tape on the lower surface for the purpose of boundary-layer transition control.

Flap settings are selected by means of the black handle on the left cockpit wall. Pivot the handle down to unlock so that it may be moved forwards or backwards.

The flap settings are marked by 1, 2, 3, 4, N, 5, 6 and L above the position pointer.



Negative flap setting for high speed



Flap in landing setting

### Trim

There is a trim control for the longitudinal trim. To set the trim, press the trim release lever at the control stick when flying at the desired air speed. A trim indicator is fitted at the left cockpit wall at the seat.

While pressing the stick mounted trim release lever, the trim can also be adjusted by sliding the trim indicator knob to a desired position.

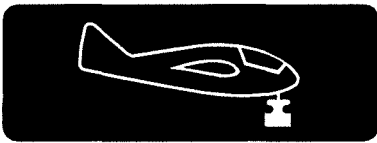

Trim nose heavy

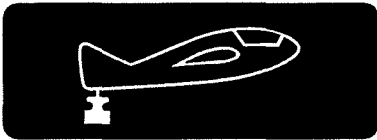

Trim tail heavy

### Airbrakes

The airbrakes are operated by a blue handle mounted at the left cockpit wall.

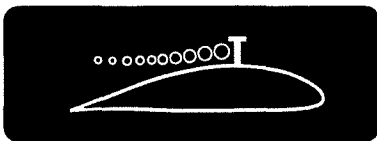

Pull the blue handle to extend the airbrake paddles.



When the airbrake handle is pulled back to its fullest extent, it will also actuate the hydraulic disc brake of the main wheel.

**Launch cable / tow hook release**

High on the left cockpit wall you will find the yellow cable release knob.



Yellow T-handle for cable release

Pulling the yellow knob will open one or both of the towing hooks.

To allow the launch cable to be attached, pull the yellow knob back to the stop and then let it go, allowing the towing hook to snap shut and lock.

**Opening and closing the canopy**

The canopy is locked by means of the two white lever handles fitted to the canopy frame at the right and left.



White levers for opening the canopy

To open the canopy, both levers are pivoted to the rear and the canopy is pushed up.

**Emergency canopy jettison**

To jettison the canopy, pull jettison levers (red levers mounted at either side of the canopy frame) and pull canopy up!!



Red levers for jettisoning the canopy

Operating the red jettison levers will automatically open the white locking levers, leaving the canopy resting loosely on the cockpit rim. The "Röger-hook" enables a controlled jettison of the canopy.

**NOTE**

*If possible, do not leave the aircraft parked or unattended with canopy open, because:*

- 1. the canopy could be slammed shut by a gust of wind which might shatter the Perspex.*
- 2. at certain elevations of the sun the canopy could act as a lens concentrating the sun rays, which might harm instruments and equipment severely.*

**NOTE**

*Operating the jettison levers allows the canopy to be removed for easy access when inspecting instruments.*

**Ventilation**

There are two means of ventilation in the cockpit.

A ventilation flap is located at the front of the canopy. This is operated with the small black knob on the instrument panel. This ventilation also serves as a demister for the canopy.

A second ventilation nozzle adjustable in flow rate and direction is fitted on the right cockpit wall. Closing this nozzle increases the demist effect of the front vent.



Knob for ventilation; Pull to open

**7.3 Instrument panel**

For safety reasons, only a FRP panel made in accordance with the lamination scheme specified by the manufacturer may be used.

Instruments of more than 1kg (2.2 lbs) need additional support beyond the screws provided. This can be done by means of aluminium straps fixed to the stainless-steel canopy support beam.

Issue: 01.11.2020 TMÖ  
Revision:

**7.6**



Equipment with operating controls must be fitted conveniently within reach, when the pilot is secured in the seat safely.

Flight monitoring instruments, like ASI and altimeter, must be mounted within the pilot's field of view. The ASI should be mounted high in the panel in a preferred position.

#### 7.4 Landing gear system

The landing gear is extended and retracted, and locked at either position, by means of the black handled lever mounted at the right-hand cockpit wall.

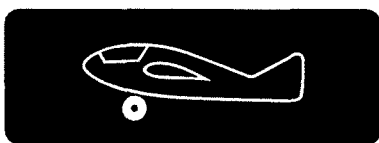

Landing gear extended  
(lever forward)



Landing gear retracted  
(lever aft)

**NOTE**

Remember the crib >  
To **retract** landing gear =

**Retractable** landing gear  
**retract** lever

Tire pressures:

Main wheel:	3,5 bar ± 0,1 bar (50.8 psi ± 1.5 psi)
Fixed tail wheel:	2,5 bar ± 0,1 bar (36.2 psi ± 1.5 psi)
Retractable tail wheel:	4,0 bar ± 0,1 bar (58.02 psi ± 1.5 psi)

The Valves of main wheel and tail wheel are on the left hand side. The vent of the tail wheel is only accessible when the tail wheel is removed from the fuselage. Optionally the fuselage can be modified in such a way, that a gap in the seam of the tail wheel fender allows direct filling (see Maintenance Manual Section 2.5.4).

## 7.5 Seat and safety harness

### Seat and seating positions

Tall and medium sized pilots can sit comfortably and may adjust the back rest on its lower end (three positions with screws) and on the upper end by actuating the handle in the right cockpit wall. The latter is also possible in flight. The backrest requires the use of an appropriate parachute or a rigid foam cushion.



Adjustment crank of the backrest

#### Adjust backrest aft:

Release backrest, unlock ratchet lever und guide foreward up to the intended position. Ensure correct engagement of the ratchet lever!

#### Adjust backrest forward:

Release backrest, unlock ratchet lever und guide aft up to the intended position. Ensure correct engagement of the ratchet lever!

Optimum seating position is achieved when the upper thighs contact the wedge of the seatpan and the backside fits into the corner of the cockpit floor. The anchor points of the lap straps are fixed in such a way relative to the seatpan that submarining (sliding forward from underneath) is extremely remote.

The geometry of the seat is designed such that tall pilots are comfortably seated. We recommend the use of thin parachute packs of the latest type.

Very short pilots must adjust their seating position by means of a firm cushion (energy absorbing, semi-rigid foams are optimum) so that all controls are within comfortable reach and that their view to the outside is improved. A small pilot is positioned high enough when the instrument panel does not restrict the forward view and the headrest contacts your head at eye level. The instrument cover is so designed that the panel edge is in line with the front contour of the canopy glass.

For all sizes of pilots it is very important to adjust and lock the backrest, to prevent being moved backwards during initial take-off acceleration (winch-launch). For the same reason, cushions used must be sufficiently rigid and stiff.

### Headrest

The AS 33 Es is equipped with an adjustable headrest. To get access to the upper baggage compartment, the headrest can fold down forward at a hinge which connects the headrest to the backrest.

Prior to the flight, the headrest should be adjusted so that a comfortable head position is reached in every case. The headrest should touch the head at eye level to ensure optimal support. The adjustment is done by a rotary handle on the back of the headrest. On the lower end of the handle a base element with rotary free movement is installed which is held by a magnet at the backrest. The pilot must pay attention that the base element is properly aligned with the contact area.

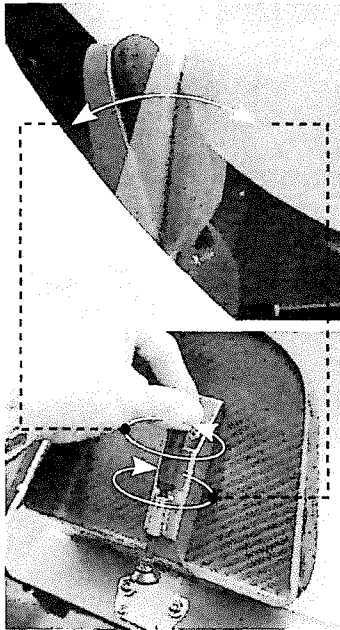

The slope of the headrest can be adjusted with the black rotary handle on the back.

### Safety harness

Correct fastening of seatbelts in gliders (recommendation by "TÜV Rheinland"):

- ① Sit down in the seat.
- ② Put pelvic belts on and fasten them as tightly as possible.
- ③ Make sure that the pelvic belts are lying on the pelvis and the buckle is in the middle of the pelvis.
- ④ Plug shoulder belts into the central buckle and fasten them with significantly lower tension than the pelvic belts.

#### **IMPORTANT**

*In doing so, the buckle must not be pulled up towards the soft parts of the body!*

- ⑤ When the belt system loosens during the flight: always refasten the pelvic belts first and then the shoulder belts.

Check every time that each individual strap is properly secured in the harness lock. Check from time to time if the lock opens easily under simulated load.

### Automatic parachute static line

An anchor ring is provided for the static line (ripcord) of an automatic parachute. It is located on the right hand (in flight direction) of the main bulkhead underneath the lift pin tube.

## 7.6 Pitot and static systems

A multi-probe is located in the vertical fin, delivering static-, pitot- and TE-pressure. Static ports are located laterally in the tail cone. A pitot tube is located in the fuselage nose.

The airspeed indicator is driven by the pitot pressure from the tube in the fuselage nose and by the static pressure from the tail cone.

Pneumatic and electric variometers are fed from the probe in the vertical fin.

Ensure that the multi-probe is fully pushed home in its seating in the fin. From time to time, the inner end of the probe should be lightly lubricated with Vaseline or a similar lubricant, in order to save the O-ring gaskets from wear.

## 7.7 Airbrake system

The AS 33 Es is equipped with Schempp-Hirth type airbrakes (four elements) on the upper side of each wing. They efficiently increase sink rate, but also increase stall speed by 5-10km/h (3-5 kts, 3-6 mph). They have only small effect on trim. Hand forces above 200 km/h (108 kts, 124 mph) can become larger than 20 daN. If hand forces are too high, reduce airspeed. See section 2.9 for max load factors with airbrakes extended.

The airbrake handle also actuates the hydraulic disk brake of the landing gear, when it is fully pulled back.

Fig. 7-6-1 Pitot and static lines and instrument connections

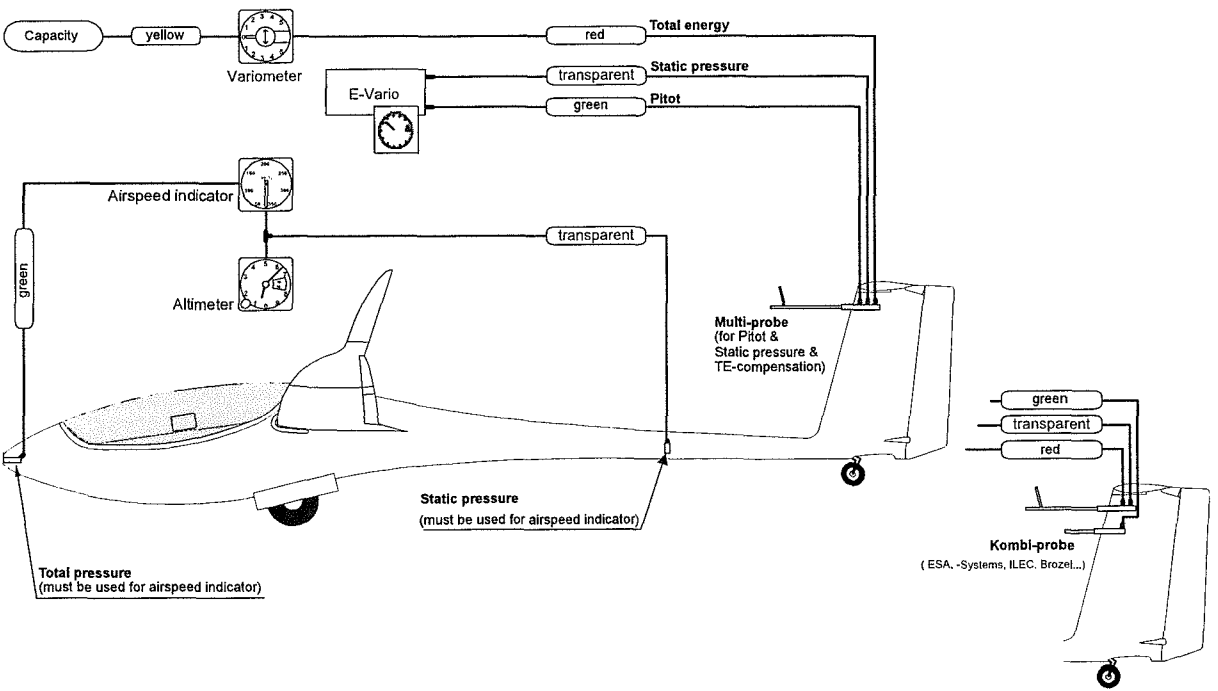

Issue: 01.11.2020 TMO  
Revision:

## 7.8 Baggage compartment

The fuselage of the AS 33 Es has two options for carrying baggage. Hard objects may not be carried in the two baggage compartments without being securely fastened!

### Left of landing gear box

This baggage compartment is only available when the aircraft is flown without installed fuel tank. In this case the maximum load may not exceed 5 kg (11 lbs).

Baggage compartment load  
**max. 5 kg**  
(11 lbs)  
only soft parts

Identification of lower baggage compartment

### In front or on top of the spar

The baggage load in this compartment may not exceed 12 kg (26 lbs).

Baggage compartment load  
**max. 12 kg**  
(26 lbs)  
only soft parts

Identification of upper baggage compartment

## 7.9 Water ballast system

The inner wings have integrated tanks of about 134 L (35.4 US-gal.) capacity in total. The 18m-outer wings are also equipped with integrated tanks having a total capacity of about 36 L (9.5 US-gal.). As an option, a tail tank with 5 L (1.3 US-gal.) can be installed to counteract the nose heavy moment of the wing water ballast.

The valves of all wing and fuselage water tanks are operated by electrical servo units. The control system is located at the right cockpit wall in front of the landing gear operating lever with its own control panel. The usage of the water ballast system is described within section 4.5.6.

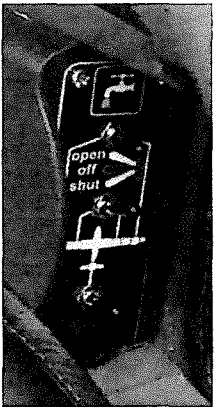

The control system of the water ballast is supplied with current by the 12V on-board electrical system. Electrical protection of the system is achieved by a fuse which is located at the lower region of the control panel.

The electrical system of the water ballast control is designed as a bus-system so that all valves are connected parallel to a central main bus.

At the separation from wing and fuselage as well as from inner wing and outer wings, electrical connectors are installed which automatically connect when the aircraft is rigged.

The valves for the wing water tanks are located directly at the outlet on the lower wing shell. The actuation of the valves is incorporated into the root rib of the wings. The valve for the tail tank is incorporated into the lower bearing block of the rudder. The belonging outlet is located at the fuselage bottom directly behind the tail wheel.

On the upper wing surface of the inner and 18m-outer wings are openings for ventilation and drying of the water tanks, which may also be used for filling ballast water. A screwed in cover closing the openings must be secured with tape in flight.

At front of the root rib from inner and outer wings there is a drainage hole, which enables water left in the tank to drip out of the wing, when the glider is stored in the trailer. When the glider is rigged, these openings must be closed manually with the pins 290.76.0018.

The ventilation opening for the water ballast tanks of the 18m-outer wings is a hole in the outer shell of the winglets (upper region). To connect the water tanks with this opening there is a coupling joint at the transition from outer wing to the winglets. Pay attention to the o-ring installed at this joint when rigging the aircraft.



The ventilation of the inner wings water ballast tanks is done collectively by a central hole in the upper fuselage skin which is located about 6 cm behind the canopy frame. To connect the ventilation hole and the tanks a coupling joint at the transition from wing to fuselage is installed. Pay attention to the sealing element installed at this joint when rigging the aircraft.

The ventilation of the tail tank is done by a hole in the upper region of the vertical tail on the left side.

All ventilation holes are marked with a red circle. They have to be checked for free airflow through the holes before a flight with water ballast is performed.

The position of the ventilation holes allows the wing tip to be put on ground without losing water through the ventilation openings.

## 7.10 Electrical system of the avionic

The electrical system for the AS 33 Es avionics is a 12 volt system using one battery as standard which have to be installed:

- Avionic-Battery 1

This battery is installed in a special compartments below the footrest. It supplies the electronic instruments. For electrical protection a 10A fuse is installed directly at the battery.

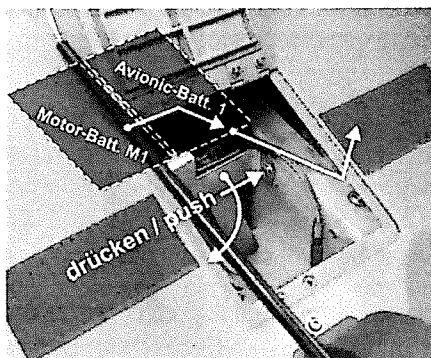

The battery or specifically the battery mounting is accessible through a cover at the footrest. The battery is slid in together with the engine battery M1 into a specially made mounting. The securing of the batteries is done by an aluminium bracket which locks into the FRP structure.

Additionally there are two more batteries available as an option:

- Avionic-Battery 2

This battery is installed in a special compartment in the right side of the upper baggage compartment. It supplies the electronic instruments. Electrical protection is provided by a 10A fuse is installed directly at the battery.

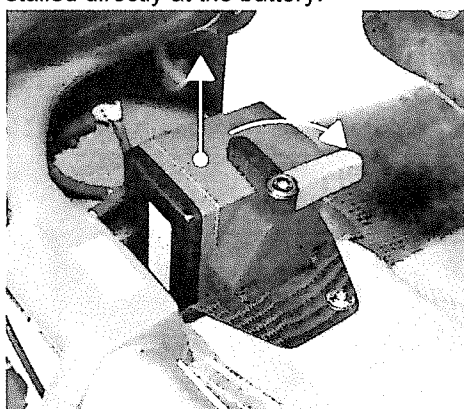

The battery is inserted into a specially made deepening of the baggage compartment bottom. The securing is done by a clamping lever which swivels above the battery when it's inserted. An integrated detent mechanism prevents unintended twisting of the lever.

- Avionic-Battery 3

This battery can be installed in a special compartment at the upper end of the vertical tail. It can also supply the electrical instruments. For electrical protection a 10A fuse has to be installed directly at the battery.

The battery must perfectly fit to the compartment. If necessary, additional foam must be used to prevent the battery from shifting.

**NOTE**

*For flights with the engine removed the avionic-battery 2 becomes standard. The avionic battery 1 and 3 are still available optionally. When they are used note their effect on the centre of gravity (see section 6.3)!*

For charging, the batteries must be removed from the fuselage. Alternatively the charging can be also performed by using the optional charging sockets. Depending on the custom design this socket is installed in the instrument panel and / or on to the right root rib of the fuselage. Details on the electrical connection are shown in the maintenance manual.

Issue: 01.11.2020 TMÖ  
Revision: TM 3 28.04.21 TMÖ

During the flight the battery selector switch installed in the instrument panel can be used to decide which battery is used to supply the electrical instruments. The markings on the switch complies with the nomenclature used above. If not all the batteries are installed the respective switch positions does not work! When required, the avionic electrical system can be supplied from the engine battery M1 (see section 7.14) when the selector switch is turned to the appropriate position. The battery selector switch also works as a main switch for the electrical avionic system. Position "OFF" means that the avionic system is out of service.



Marking of the main and battery selector switch

Optionally there can be solar cells installed on the engine compartment doors of the AS 33 Es. In this case an additional selector switch is installed in the instrument panel. This switch can be used to select which battery is charged by the solar system. It is recommended to charge one of the two engine batteries to be sure that maximum battery capacity is available for the sustainer engine.

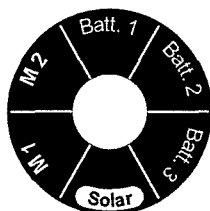

Marking of the selector switch for the solar system

Every electrical instrument has to be protected by a suitable fuse. The fuse depends on the device – the instructions of the respective manufacturer need to be observed!

The circuit diagram for the electrical system of the avionic in the AS 33 Es and the connection to the electrical system of the engine are shown in Fig. 7.10-1.

Fig. 7.10-1 Circuit diagram

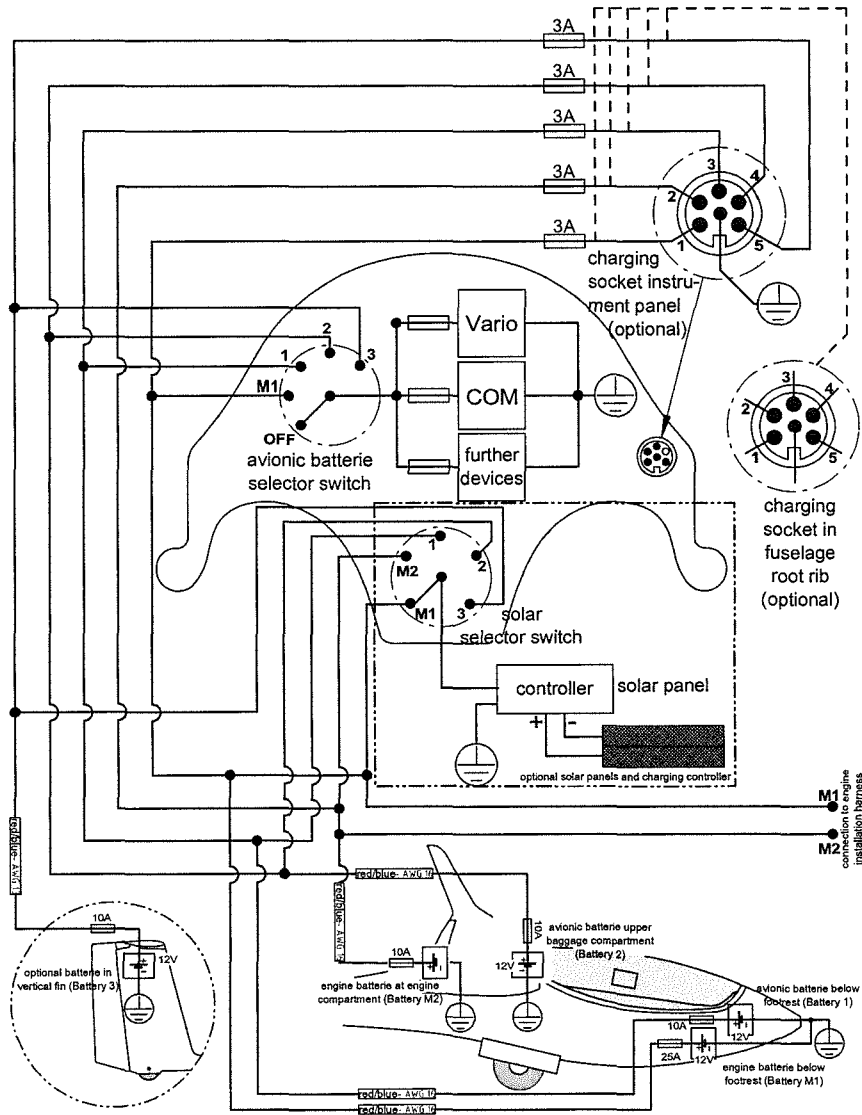

Issue: 01.11.2020 TMÖ  
Revision:

## 7.11 Miscellaneous equipment

### Removable trim ballast (optional)

If required, the AS 33 Es can be equipped with a fitting for lead trim ballast plates which can be bolted into place in front of the rudder pedals. Pilots not meeting the minimum loading can compensate the missing load. Details on that can be found in section 6.3.

A maximum of 8 trim plates are allowed for installation.

### Trim mass (battery) mounted in the fin

Fitting a trim mass (or battery) in the fin increases the minimum cockpit seat load. A detailed calculation of in-flight c.g. is required in this case (see section 6.3)! Only use trim masses that were prepared for the individual glider.

The foam buffer fitted over the mass or battery secures it upwards. This plastic foam pad must not be forgotten when changing or replacing batteries. You should also ensure that there is adequate plastic foam seating under the battery to protect it from hard knocks!

The maximum weight allowed to be installed in the fin compartment is 3.6 kg (7.9 lbs).

#### **WARNING**

*Unless otherwise indicated, the loading placard in the cockpit shows the lower minimum loading without any trim mass at the vertical tail. The increased minimum loading or respectively the in-flight c.g. have to be evaluated!*

### Oxygen

A seating for an oxygen bottle is optional, but can be retrofitted any time with little cost (see maintenance manual, section 2.7). The position of the bottle is behind the pilot's right elbow, beside the wheel-box. The bottle must be immovably attached between a rear FRP support and a clamping ring. Depending on support and clamping ring, one German 3-litre oxygen bottle, 100 mm dia. or one US bottle of 4.25" dia, 16.5" long or a US-bottle 4.3/16" dia., 17" long can be accommodated.

Fitting the oxygen bottle, ensure that it is properly installed and securely anchored.

**WARNING**

*When the oxygen bottle is removed the cover for the hole in the bulkhead must be installed as otherwise loose objects may get from the cockpit rearward into the control circuits.*

**NOTE**

*Fitting of oxygen equipment only causes a minimal change in the empty-mass c.g. position! See section 6 for more information.*

When flying at greater heights while using the oxygen installation, it should be borne in mind that any particular system may only be suitable for a limited altitude range. The makers' instructions should be complied with.

## 7.12 Power-plant

When retracted the power-plant is accommodated in the engine compartment in the fuselage behind the wing. It is extended and retracted by means of an electric jack.

The following control elements are provided for the power-plant:

- the control console on the pilot's left hand side with the main switch, engine switch and manual fuel valve button
- the power-plant instrument fitted in the instrument panel
- the rear view mirror

### Control console

The control console is placed at the pilot's left hand side underneath the yellow cable release knob. The engine switch is the single control to be operated to start and stop the power plant.

The pilot controls the following functions with the engine switch:



- (1) Extension and retraction of the power plant
- (2) Switching the ignition
- (3) Engaging the starter

In addition, some functions are automatically executed depending on the engine switch position and the engine status:

- (4) Opening and closing of the fuel valve, braking and vertical aligning of the propeller as well as engaging the decompression valves

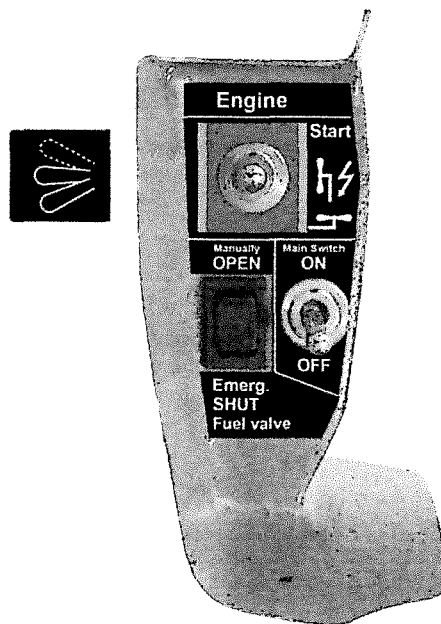
Fig. 7.12-1 View of the control console



Element	Position	Effect
Main Switch	OFF	Electric power off
	ON	Electric power on
Engine Switch	"OFF" 	brakes and aligns propeller, retracts engine
	"ON" 	extends engine, ready for operation / engine running
	Start (spring-loaded)	engage starter; if not extended the same as position "ON"
Manual Fuel Valve	manual open	Opens fuel valve
	Emergency SHUT	Closes fuel valve

**CAUTION**

The fuel valve is operated automatically. It has to be operated manually only in case of an. If the fuel valve is manually switched, the power-plant instrument gives a warning. After a manual fuel valve actuation the engine main switch has to be turned off to reactivate the automatic operation.

The manual fuel valve is operated independently from other switches or logics.

**CAUTION**

The engine switch directly switches the ignition – independent from other switches or logics. In the positions "ON"  and "Start" the ignition is on.

**CAUTION**

If the propeller is turned while the system is powered off (e.g. pre-flight check), it has to be aligned vertically before switching on again and retracting. The retracting is not started until the security query "PROP.Pos RETRACT?" of the power-plant instrument is confirmed.

Issue: 01.11.2020 TMÖ  
Revision:



*If the propeller is turned at least one full rotation while the system is on (e.g. windmilling), it knows its vertical position and aligns automatically. In this case no security query is shown before retracting.*

### **Power-plant main switch**

The main switch is located in the power-plant control console and is labelled "Main Switch". (see page 7.21).

### **Power-plant instrument**

The power-plant instrument of the AS 33 Es fits in an Ø57mm housing in the instrument panel. It has several control, monitoring and display functions:

- (1) It controls the electric jackshaft, starting and stopping of the engine, fuel valve and fuel pump depending on the position of the engine switch and the state of the power-plant.
- (2) It influences the ignition. Independently from the engine switch it shuts down the ignition, whenever the engine is not completely extended or the rotational speed exceeds the maximum permissible RPM.
- (3) It displays the state of the power-plant (retracted or extended, rotational speed, fuel quantity, voltage, elapsed time) and supplies warnings in case of exceeding limits or improper operation.

For few seconds after power on, the instrument switches all LEDs and the alarm sound on.

#### **CAUTION**

*Continuous alarms (=Caution) sounds if limits are exceeded or are too low (rotational speed, fuel quantity, voltage, jackscrew runtime, fuse).*

*Pulsing alarms sounds together with handling notifications.*

*See LCD display for explanation (see page 7.24).*

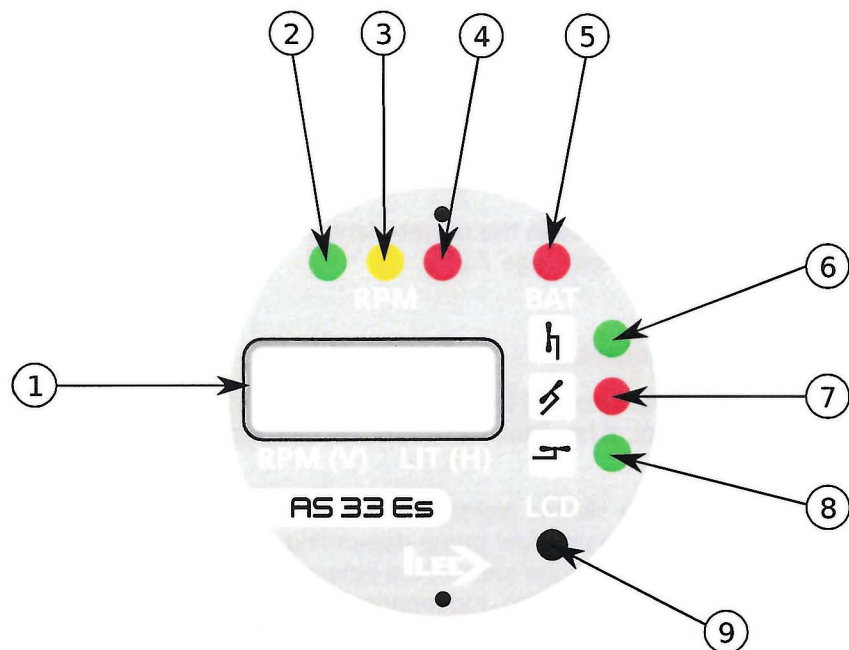
**Front-display of the power-plant instrument:**

- 1 LCD Display
- 2 LED green, for green rotational speed range
- 3 LED yellow, for yellow rotational speed range
- 4 LED red, for maximum rotational speed
- 5 LED red, for low voltage
- 6 LED green, for fully extended power-plant
- 7 LED red, for error messages
- 8 LED green, for fully retracted power-plant
- 9 Button for display selection

Numbers in brackets in the text refer to the numbers of this figure.

**Control of electric jackscrew**

To extend or retract the power-plant, bring the engine switch into the corresponding position (see fig 7.12-1).

The green LED (6) indicates that the power-plant is fully extended. The green light (8) indicates the power-plant is completely retracted.

If the power-plant instrument does not receive a signal from the end-switch for an unusually long time, it stops the jackscrew. The red LED (7) flashes, an alarm sound sets in, and the LCD (1) displays SWITCH R respectively SWITCH E. The possible fault may be either a faulty end-switch, a jammed engine mount or low voltage. The alarm can be acknowledged with button (9), restarting the jackscrew again. As long as there is no signal from the end-switch saying "fully extended", the ignition is blocked. (see section 3.7)

Concerning the message FUSE, see section 7.14.

**Influence on ignition**

The power-plant instrument features its own relays to block ignition independently from the pilot's ignition switch. It blocks ignition as long as the power-plant is not fully extended and as soon as the maximum rotational speed is exceeded.

**CAUTION**

*If the current supply of the power-plant instrument is interrupted, it cannot block the ignition.*

**Control of the electrical fuel pump**

To support the pneumatic fuel pump for the start, the power-plant instrument activates the electric fuel pump under the following condition:

- The engine switch is in position "ON" or "Start" and the rotational speed is below 2000rpm.

To save energy during non-use, the electric fuel pump is turned off after 30sec. If the engine is then started, the fuel pump is switched on again.

### Display of power-plant status

Section 2.5 describes the modes of the LCD-Display (1).

The sensor system of the starter motor measures the rotational speed. It is displayed in the permanent display on the left side. When the engine runs with its target speed the green LED (2) lights. The yellow LED (3) warns of approaching the maximum RPM. When reaching the maximum rotational speed, the ignition is switched off and the red LED (4) illuminates.

The red LED (5) illuminates, whenever the battery voltage falls below 11,5V.

### Fuel monitoring

A sensor monitors the content of the fuselage tank. The display is calibrated for flight attitude. Therefore, on the ground, it deviates from the actual fuel quantity. Also in flight the pitch attitude varies, thus a calibration more accurate than by half a litre (0.13 US Gal.) is not possible.

When the fuel quantity in the fuselage tank sinks below 1.5 litre (0.4 US-gal.) for over 5 s, an alarm resounds and the display starts to blink. The alarm can be turned down with button (9) for four minutes.

The optional fuel tank extension is not equipped with an own fuel level sensor. Therefore, the engine control unit will show a quantity of 7,0 litre until the extension is fully drained.

The calibration of the fuel sensor was done with fuel-oil mixture based on AVGAS 100LL. Mixtures based on other fuel qualities may lead to deviating indications. Thus the deviation is largest with full tank and zero with empty tank.

The power-plant instrument can be set to other fuel qualities. The fuel tank must be filled full and the power-plant retracted. Press button (9) nine times until Calibr. ? appears at the display. Then keep button (9) pressed for five seconds to perform the calibration.

After the calibration, the power-plant instrument assumes that the signal from the fuel sensor corresponds to a full tank. With a full tank, the difference between flight and ground attitude is small

**Display- and warning-ranges of the power-plant instrument:**

Type	Display-range	optical	acoustic
Rotational speed	400 – 9990 rpm	See section 2.5	> 5400 rpm permanent alarm
Fuel quantity	0 – 7 Ltrs	< 1.5 Ltrs LCD blinks	< 1.5 ltrs permanent alarm
Engine battery voltage	10 – 15 V	< 11.5 V LED (5) blinks	< 11.5 V permanent alarm
Starter battery voltage	0 – 63,75 V	< 11.0 V LED (7) blinks	< 11.0 V permanent alarm
Starter motor current	0 – 255 A	> 220 A LED (7) blinks	> 220 A permanent alarm
Starter motor temperature	0 – 255°C	> 100°C LED (7) blinks	> 100°C permanent alarm
Starter controller temperature	0 – 255°C	> 110°C LED (7) blinks	> 110°C permanent alarm
Propeller position	0 – 125		
Elapsed time counter	Counts above 2000 rpm		

Type	Display-range	optical	acoustic
Running time of jackscrew	LCD displays: "SWITCH R" or "SWITCH E"	> 20 s LED (7) blinks	> 20 s permanent alarm
Both end-switches closed	LCD displays: "SWITCH 2"	LED (7) blinks	permanent alarm
Circuit breaker of jackscrew disengaged	LCD displays: "FUZE"	LED (7) blinks	permanent alarm
Missing signal of fuel sensor	LCD displays: "INS_TANK"	LED (7) blinks	permanent alarm
Starter motor blocked	LCD displays: "MOT - LOCK"	LED (7) blinks	permanent alarm
No CAN-Bus-connection to starter controller	LCD displays: "ERROR CAN_MISS"	LED (7) blinks	permanent alarm
No signal of the starter sensors	LCD displays: "ERROR SEN- SOR"	LED (7) blinks	permanent alarm
Manual fuel valve operation	LCD displays: "MANUALLY FUEL LOCK"	LED (7) blinks	permanent alarm

### Rear-view mirror

A rear-view mirror in the cockpit is necessary to check the correct position of the propeller before retracting the power-plant.

### 7.13 Fuel system

An overview of the AS 33 Es fuel system is shown in Fig. 7.13-1 at the end of this section.

The fuel system consists of a fuselage tank with 7.0 Ltrs (1.85 Us-gal.) capacity. This fuel tank is permanently installed between the landing gear box and the left cockpit wall. When the backrest is folded forward the fuel tank can be accessed. The fuel quantity is sufficient for an engine run of about 35 minutes. The refuelling is done by the integrated automatic re-fuelling pump.

Optionally an extension for the fuel tank can be installed so that the fuel quantity on board is increased to 11,0 Ltrs (2.9 Us-gal.). This U-shaped fuel extension is permanently installed in the upper region of the upper baggage compartment and drains directly to the fuel tank next to the landing gear box.

The drainer is located below the left landing gear door and directly connected to the lowest point of the fuselage tank. It is easily accessible when the main landing gear is extended.

In the upper region of the fuselage, directly behind the canopy frame, an expansion tank with 0.2 Ltrs. (0.05 US-gal.) capacity is installed. This tank also includes the sensor for the automatic control of the integrated refuelling system. The ventilations line, starting from the expansion tank, ends directly next to the drainer below the left landing gear door.

In the left fuselage side there are the electric fuel pump and the (electric) fuel cock. Also the electric pump for the refuelling is installed there as well as the fine fuel filter. The electric fuel pump runs automatically when the power-plant is extended or started and stops when the engine is running. If the power-plant is extended but not started, the electric fuel pump stops after 30 sec to save the engine battery.

#### **Refuelling**

For refuelling the fuselage tank only the integrated automatic refuelling system may be used!

The filler connection for the external fuel filler hose (AS-P/N 99.000.7275) is located in the forward upper region of the engine compartment. It is recommended to extend the power-plant so that the doors of the engine

compartment are open and the fuel level indication on the power-plant instrument is available.

Connect the fuel refilling hose including a fuel filter to the coupling at the rear end of the engine compartment and refuel from a canister

The refuelling system is operated by a switch which is integrated in the instrument panel. This switch has three positions:

- AUTOMATIC:** The refuelling system is active and will be automatically shut-off when fuel tank is fully filled.
- OFF:** The refuelling system is shut-off.
- MANUAL:** The automatic control of the refuelling system is deactivated and refuelling is performed manual.

It is recommended to use the automatic function of the integrated refuelling system. The automatic switch-off prevents that the fuselage fuel tank is unintentionally overfilled. To provide this feature the expansion tank is equipped with a sensor which recognizes when fuel rises from the fuel tank up to the expansion tank and switches off of the refuelling pump.

To check the fuel quantity during the refuelling process the power-plant instrument must be switched on. Alternatively the fuel quantity can be checked by the transparent stripe directly at the fuel tank.



Fig. 7.13-1 Fuel system

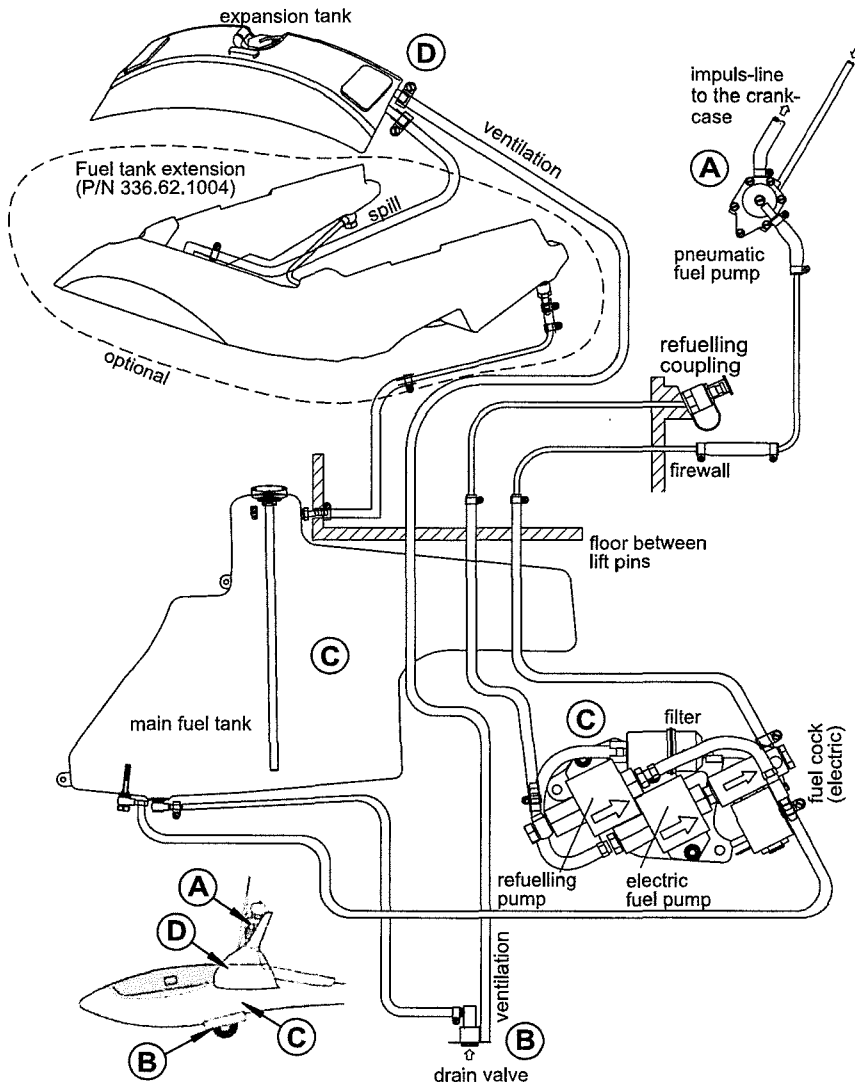

## 7.14 Electrical system of the power-plant

The electrical system of the power-plant for the AS 33 Es is a 12 volt system using two batteries as standard which have to be installed when the power-plant is installed:

- Engine battery M1

This battery is installed at a special compartments below the foot-rest (right-hand in flight direction). This battery supplies the power-plant system (via the main switch). Therefore, a 25A fuse is located immediately at the battery. With the battery selector switch this battery can also supply the avionic electrical system. However, it is recommended not to do that because the power-plant cannot be extended and retracted if the voltage of the battery drops too low.

The power supply of the jackscrew branches off directly from the power-plant battery. The electric line and the jackscrew are protected by an automatic circuit breaker. This circuit breaker is located at the relays under the seatpan, and it is remote controlled by the power-plant instrument.

In case the circuit breaker disconnects, the red LED (7) blinks, an alarm sound sets in and the word "FUSE" appears on the display (1). The alarm can be acknowledged with button (9), see section 7.12. If the power-plant instrument tries to extend or retract the engine (depending on the engine switch and system state) it will then also try to reset the circuit breaker and to restart the jackscrew (see also section 3.7).

- Engine battery M2

This battery is located in the upper forward region of the engine compartment between the engine mount and powers the starter motor of the power-plant. The starter battery is independent from the remaining electrics of the AS 33 Es and connected via a relay directly with the controller of the starter (black box located in the left wall of the engine bay). During normal use this relay is controlled by the power-plant instrument. If in case of an emergency the power-plant main switch is toggled off and the relay also switches off independently from the instrument.

For charging the batteries must be removed from the fuselage. Alternatively the charging can be also performed by using the optional charging sockets. Depending on the custom design this socket is installed on the instrument panel and / or on the right root rib of the fuselage. Details on the electrical connection are shown in the maintenance manual.

**CAUTION**

*If the starter battery is faulty or not mounted or if the power electronics of the starter are not connected, the system is inoperable and will neither extend nor retract.*

**NOTE**

*If the power-plant is extended, removal of the starter battery is very cumbersome. It is much easier, if the power-plant is retracted. Alternatively, the starter battery can be charged via the port in the instrument panel instead of removing it.*

**NOTE**

*For flights with removed power-plant the engine batteries M1 and M2 are not necessary and should be also removed from the aircraft. In that case, the avionic battery 2 in the upper baggage compartments becomes standard.*



## **Section 8**

### 8 Sailplane handling, care and maintenance

- 8.1 Introduction
- 8.2 Sailplane inspection periods
- 8.3 Sailplane alterations or repairs
- 8.4 Ground handling / road transport
- 8.5 Cleaning and care

## **8 Sailplane handling, care and maintenance**

### **8.1 Introduction**

This Section contains the manufacturer's recommended procedures for proper ground handling and servicing of the sailplane. It also identifies certain inspection and maintenance requirements to be followed if the sailplane is to retain that new-plane performance and dependability.

It is advisable to follow a planned schedule of lubrication and preventive maintenance based on climatic and encountered flying conditions.

### **8.2 Sailplane inspection periods**

The national requirements regarding continuous airworthiness of the country where the sailplane is registered must be followed.

Refer to AS 33 Es Maintenance Manual, Section 4 and 7.

### **8.3 Sailplane alterations or repairs**

It is essential that the responsible airworthiness Authority is contacted prior to any alterations to the sailplane to ensure that the airworthiness of the sailplane is not compromised.

For repairs and modifications refer to the applicable Maintenance Manual AS 33 Es Maintenance Manual, Sections 10 and 11.

## 8.4 Ground handling / road transport

### **Parking**

Parking the AS 33 Es, the controls and flaps should be set neutral (flap setting 3), since the glider is equipped with elastic tape to seal the gaps at the control surfaces.

#### In the open

Parking the aircraft in the open can only be recommended when the predicted weather conditions are suitable. It should be seriously considered that securing, covering, and cleaning the aircraft before the next flight may require more effort than derigging and rigging.

For tying-down the wings, trestles (perhaps from the trailer) should be used to ensure that the ailerons cannot be stressed by the picketing ropes. It is recommended to use the optional lashing eyes. Another option is to remove the outer wings and use the mounting bar from the trailer to tie down the wings.

#### **NOTE**

*Parking in the open without protection against weather or light will reduce the life of the surface finish. Even after only a few weeks without intensive care the polyester paint finish can become brittle and develop cracks.*

#### In the hangar

If the aircraft is parked in the hangar for protracted periods, it is recommended to cover only the perspex® canopy with a dust cover, as dust covers retain moisture in wet weather for long periods. Moisture can impair the dimensional stability and even the strength of all fibre reinforced composites.

For this reason, protracted periods of parking with water ballast on board are also inadmissible! The filling and ventilation openings on the upper wing surface and the drain valves must both be opened!

#### General

When parking, carefully remove any remnants of food (chocolate, sweets, etc.) because experience shows these attract vermin which can cause damage to the aircraft.

### Road transport

Alexander Schleicher GmbH & Co. can supply dimensioned drawings of the glider which will provide all the measurements needed for building a closed trailer.

We can also supply the names and addresses of reputable trailer manufacturers. Regulation for trailer dimensions vary from country to country so be sure to provide us with correct data.

Above all, it is important to ensure that the wings are supported in properly shaped and fitted wing cradles, or at the very least, that the spar ends are securely supported as closely as possible to the root ribs. Reinforced points of the fuselage are the main wheel (remember the suspension springing!), and tail wheel; also, the drag pins (make up support bushings from plastic material like Nylon!), and the area under the canopy arch between the c.g.hook and the lap-strap area. If the aircraft is equipped with a retractable tail wheel a tail dolly must be used for storage in the trailer

For an aircraft of this quality and value, an open trailer, even with tarpaulin, cannot be recommended. Only a closed trailer of plastic or metal construction, may be considered suitable. The trailer should have light coloured surfaces and be well ventilated both while moving and while stationary so as to avoid high internal temperatures or humidity.

#### **CAUTION**

*Road transport with water ballast on board is not permitted!*

#### **CAUTION**

*In order to protect the air brake cover plates from damage the air-brakes must be closed and locked!*

#### **WARNING**

*Under no circumstances should the elevator actuator on top of the vertical fin be loaded or fixed in any way, even by soft foam cushions.*

*When designing or adapting the trailer, free movement and side clearance for the elevator actuator must be provided.*



If for example a foam block applied some load to the elevator actuator, and restricted its free movement, fatigue cracks can develop after long road transports. A workaround is urgently needed!!

The following sketch shows, how a foam-rubber block must be trimmed and glued in position. It is also important to have a strap which is connected to the trailer floor over the fuselage boom near the fin. In any case, it is necessary to guarantee the free movement of the elevator actuator. This must be so even if the stick is pulled fully back and the elevator is fully deflected upward.

Fig. 8.4-1

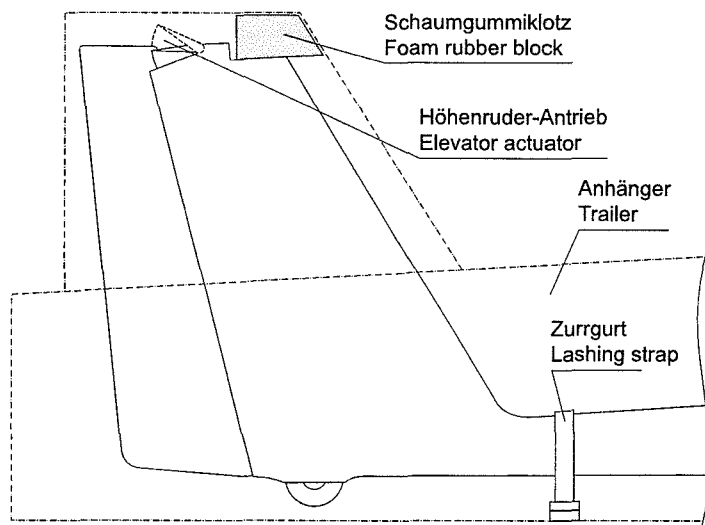

## 8.5 Cleaning and care

Contrary to the popular belief that composite materials are impervious to moisture and ultra-violet light, even modern gliders need care and maintenance!

### **Moisture-effects on the structure of the fibre-reinforced plastics and on the surface finish**

In the long run, moisture will also damage fibre-reinforced composites, as it will penetrate into the epoxy resin base and cause it to swell, which will partially burst the tight cohesion of the plastic molecules.

In particular, a combination of high temperature and humidity must be avoided! (e.g. poorly ventilated trailer becoming damp inside, which is then heated by the sun).

Neither the best quality of paint protection on the surfaces nor the internal protection of the water ballast tanks can fundamentally prevent water vapour diffusion; they can only retard the process. If water has entered the airframe and cannot be removed by means of sponge or chamois leather, the aircraft should be de-rigged and dried out in a dry but not too hot room. Also the affected part should be periodically turned over.

### **Sunlight-effects on the surface finish**

Sunlight, especially its ultraviolet (UV) component, makes the paint and the canopy plastic brittle. Do not unnecessarily expose the aircraft to strong sunlight.

The now available optional 2-part acrylic paint finish provides a significantly improved weathering resistance. Regular care is still required to maintain the good appearance and the value of the aircraft.

**Care of surface finish**

Because the white polyester gelcoat is protected by a fairly durable wax layer, it will tolerate washing occasionally with cold water, with a little cleaning solution added. The optional available 2-part acrylic paint finish may be treated in the same way. In normal use the wax coating need only be renewed annually with a rotary polisher. In moderate European conditions it will suffice if a paint preservative is applied twice a year. In areas subject to long and stronger sun exposure this should be done more often.

**CAUTION**

*The use of alkaline cleaning agents (e.g. "Meister Proper") may affect the paint surface and even penetrate into the foam of the sandwich structure and damage it. In a few cases the acrylic foam in the control surface sandwich structure was destroyed by the use of unsuitable cleaning agents. Heavy dirt should therefore be removed using a cleaning polish.*

For the care of the paint finish, only preparations containing the lowest available amount of silicone may be used.

Traces of Adhesive from Self Adhesive Tapes are best removed by means of cleaning benzine (car petrol is toxic!) or paint thinners. After cleaning, renew the wax coating.

**NOTE**

*The signal and decorative markings are built up from nitric or acrylic paint; therefore no thinners must be used and even benzine should not be allowed to act on them for prolonged periods.*

**Canopy**

The Acrylic Canopy (Plexiglas or Perspex) should only be cleaned by means of a special cleaner (e.g.: Plexus Kunststoffreiniger or Acryshield) or with lots of clean water. On no account should a dry cloth be used for dusting or cleaning.

**Safety harness**

Regular cleaning of the safety harness according to the applicable manufacturer documentation must be performed. In addition, the safety harness straps should be regularly inspected for tears, compressed folds or wear, and corrosion of metal parts and buckles. The reliable operation of the release mechanism - even under simulated load - should be tested occasionally.

## **Section 9**

### 9 Supplements

#### 9.1 Introduction

#### 9.2 List of inserted supplements

## 9 Supplements

### 9.1 Introduction

This Section contains the appropriate supplements necessary to safely and efficiently operate the sailplane when equipped with various optional systems and equipment not provided with the standard sailplane.

### 9.2 List of inserted supplements

Date of insertion	Doc. No.	Title of inserted supplement

Issue: 01.11.2020 TMÖ  
Revision: